

# OPERATION AND MAINTENANCE MANUAL FOR KV 3-4 COMPRESSORS



ENGLISH VERSION

## BACKGROUND

Never use the compressor in an inappropriate way, but only as recommended by the **Manufacturer**. The **Manufacturer** reserves the right to update the technical data contained in this manual without prior notice. Before using the compressor, carefully read the instructions in the following manual.

### IMPORTANCE OF THE MANUAL

This **INSTRUCTION MANUAL** is your guide to **INSTALLATION, USE, MAINTENANCE** of the compressor you purchased. We advise you to strictly follow all the recommendations contained in it, as the good functioning and duration of the compressor depend on the correct use and methodical application of the maintenance instructions given below. It should be remembered that, should difficulties or inconveniences arise, the **AUTHORIZED ASSISTANCE CENTERS** are at your complete disposal for any clarification or possible intervention. The **Manufacturer** therefore declines any responsibility for incorrect use or inadequate maintenance of the compressor. The **INSTRUCTION MANUAL** is an integral part of the compressor. Keep this manual for the duration of the compressor.

Ensure that any updates received by the **Manufacturer** are incorporated into the manual. Transfer the manual to any other user or subsequent owner of the compressor.







#### Preservation of the manual:

- Use the manual in such a way as not to damage all or part of the contents.
- Do not remove, tear or rewrite parts of the manual for any reason.
- Keep the manual in an environment protected from humidity and heat.

## SYMBOLS USED

The following **SYMBOLS** are used throughout the course of this publication to draw the attention of the operator to the behavior to be adopted in every operating situation

These symbols can be placed next to a text, next to a figure or at the top of the page. Pay the utmost attention to the meaning of the symbols: their function is that of not having to repeat the technical concepts or safety warnings, therefore to be considered "**reminders**". Consult the table below whenever there are any doubts about their meaning.

	<b>READ THE INSTRUCTION BOOKLET</b> Before positioning, operating or working on the compressor, read the user and maintenance manual carefully.
	<b>ATTENTION</b> highlights an important description regarding dangerous conditions, safety warnings, information of the utmost importance.
	<b>STOPPING MACHINE</b> every operation must be carried out with the machine stopped.
	<b>CAUTION MACHINE IN PRESSURE</b> each operation must be performed with the machine without pressure inside the oil separator tank (0 bar).
	<b>REMOVE TENSION</b> every operation on the machine must be carried out with the power supply switched off.
	<b>QUALIFIED PERSONNEL</b> any intervention highlighted by this symbol is the exclusive responsibility of a specialized technician.

# SUMMARY

1	GENERAL WARNINGS AND INFORMATION FOR THE USER .....	7
1.1	DEFINITION OF REGULATED RELATIONSHIPS .....	7
1.1.1	DECLARATIONS .....	7
1.1.2	WARRANTY.....	8
1.1.3	RETURNS .....	8
2	CE MARKING.....	9
3	CAUTIONS AND SAFETY WARNINGS .....	10
3.1	INSTRUCTIONS FOR SAFE OPERATION.....	10
3.2	CONTACTS AND USEFUL ADDRESSES.....	13
4	DESCRIPTION OF THE MACHINE AND OPERATING PRINCIPLE.....	14
4.1	MACHINE DESCRIPTION .....	14
4.2	OPERATING PRINCIPLE.....	15
5	DATA AND TECHNICAL SPECIFICATION.....	16
6	DIMENSIONS.....	18
7	INSTALLATION .....	22
7.1	CHARACTERISTICS AND STORAGE CONDITIONS.....	22
7.2	TRANSPORT .....	22
7.3	UNPACKING .....	22
7.4	HANDLING.....	23
7.5	LOCATION .....	23
7.6	CONNECTION AND START-UP.....	24
7.6.1	GENERAL WARNINGS.....	24
7.6.2	ELECTRICAL CONNECTION OF COMPRESSOR .....	25
7.6.3	WIRING DIAGRAM.....	27
7.6.4	AIR CIRCUIT CONNECTION .....	27
7.7	FIRST START-UP.....	27
7.8	CLEANING AND DISINFECTION .....	28
7.9	REINSTALLATION AND REUSE .....	28

7.10	DEMOLITION AND DISPOSAL.....	28
8	OPERATION AND USE .....	29
8.1	DESCRIPTION OF THE OPERATION .....	29
8.2	RANGE OF APPLICATIONS .....	29
8.3	PROPER AND IMPROPER USE .....	29
8.4	OPERATING AND ENVIRONMENTAL LIMITS .....	29
8.5	WORKSTATION AND DANGEROUS AREAS.....	29
8.6	SAFETY DEVICES AND SIGNALS .....	30
8.6.1	POSITION OF THE LABELS.....	31
8.7	COMPRESSOR LUBRICATION .....	32
8.7.1	GENERAL RECOMMENDATIONS.....	32
8.8	USING THE COMPRESSOR WITH SYNTHETIC OILS.....	33
9	INSTRUCTIONS FOR THE USER .....	34
9.1	DESCRIPTION OF THE CONTROL DEVICES .....	34
9.1.1	BUTTON LAYOUT .....	35
9.1.2	SYMBOL LAYOUT.....	36
9.2	ALARMS LIST.....	37
9.3	DESCRIPTION OF THE OPERATIONS TO BE PERFORMED .....	39
9.3.1	STARTING THE COMPRESSOR.....	39
9.3.2	PROGRAMMING .....	41
9.3.3	PARAMETER.....	42
9.3.4	STOPPING THE COMPRESSOR.....	44
9.4	REMOTE CONTROL .....	45
9.5	AUTOMATIC RESTART .....	45
10	COMPRESSOR MAINTENANCE .....	46
10.1	SCHEDULED MAINTENANCE.....	46
10.2	REPLACING OIL FILTER .....	48
10.3	REPLACING OIL SEPARATOR FILTER.....	49
10.4	CHANGING THE OIL.....	50
10.5	REPLACING THE AIR FILTER .....	52
10.6	MAINTENANCE SCHEDULE .....	53

10.7	UNSCHEDULED MAINTENANCE, COMMERCIAL PARTS, SPARE PARTS AND PERTINENT DOCUMENTATION .....	56
11	TROUBLESHOOTING .....	57
12	APPENDIX .....	59
12.1	MAINTENANCE CHECK SHEET .....	59

# **1 GENERAL WARNINGS AND INFORMATION FOR THE USER**

## **1.1 DEFINITION OF REGULATED RELATIONSHIPS**

### **1.1.1 DECLARATIONS**

The compressor must be used exclusively as indicated in this manual. This manual must be kept on hand in a known, easily accessible place because it should be used throughout the machine's entire working life.

For any request, always indicate model and serial number.

---

## **DECLARATION OF CONFORMITY**

ITALYCO Srl, the manufacturer, on its own responsibility, declares that the air compressor identified by the label on the front page of this document, complies with the essential requirements laid out in the following DIRECTIVES – STANDARDS written in the certificate of conformity attached to the machine.

ITALYCO Srl holds the relevant technical dossier.

---

### **1.1.2 WARRANTY**

ITALYCO Srl guarantees its products from manufacturing or design defects for a period of 24 months from the date of initial start-up. To inform ITALYCO Srl of this date, fill out the special form supplied with the machine technical documentation and send it in.

If no communication is received, the warranty shall be recognized for 12 months starting from the date on which the unit was shipped; that is the date indicated on the ITALYCO Srl invoice.

The warranty does not cover parts subject to wear.

Repair works covered under the warranty can only be performed by ITALYCO Srl or a ITALYCO Srl Authorized Service Centre.

Shipment of any product being returned for service under the warranty must be authorized in advance, and in writing, by ITALYCO Srl. Moreover, ITALYCO Srl, in its unquestionable wisdom, can decide whether to authorize such shipment or have one of its Authorized Service Centres do the work.

In both cases, shipment to ITALYCO Srl must be made carriage paid with shipping costs charged in the invoice. Repairs or replacements covered by the warranty include free replacement of parts of the machine that are recognized as defective.

The warranty does not cover damages caused by negligence, by incorrect use or installation or by not compliance with the warnings indicated in the “Operation and Maintenance Manual”. Moreover the warranty is voided if modifications or repairs are made with not original ITALYCO Srl spare parts or performed by anyone not authorized to do so by ITALYCO Srl.

Defective parts replaced under the warranty are retained by the Authorized Service Centre. The warranty does not cover repairs or reimbursement for damage due to shipping (to or from the Authorized Service Centre). The warranty does not cover any type of reimbursement for injuries or damages to people or things derived from improper use of the model purchased or due to machine down time (the customer must take steps to prevent this). Service covered under the warranty is guaranteed only to purchasers who have met their contractual and administrative obligations and who are able to show the documentation certifying the purchase period. This is the only valid warranty recognized by ITALYCO Srl COURT HAVING JURISDICTION.

For any disputes the competent court is that of Bologna, Italy.

### **1.1.3 RETURNS**

Returns are made using the RMA (return material authorization) procedure.

To open said procedure, the customer must send a request to ITALYCO Srl.



## 2 CE MARKING

The CE marking certifies that the compressor complies with the health and safety requirements outlined in the European Directives indicated in the EC declaration of conformity.

The marking is printed with silver lettering on a black polyester adhesive label (L:90mm H:80mm- L:3,54in, H:3,14in).

The label is placed as indicated in figure 1 and bears the following information:

- **Manufacturer name**
- **CE marking**
- **Compressor model**
- **Serial number**
- **Maximum working pressure**
- **Power supply voltage and frequency**
- **Nominal power**
- **Weight**
- **Manufacture year**

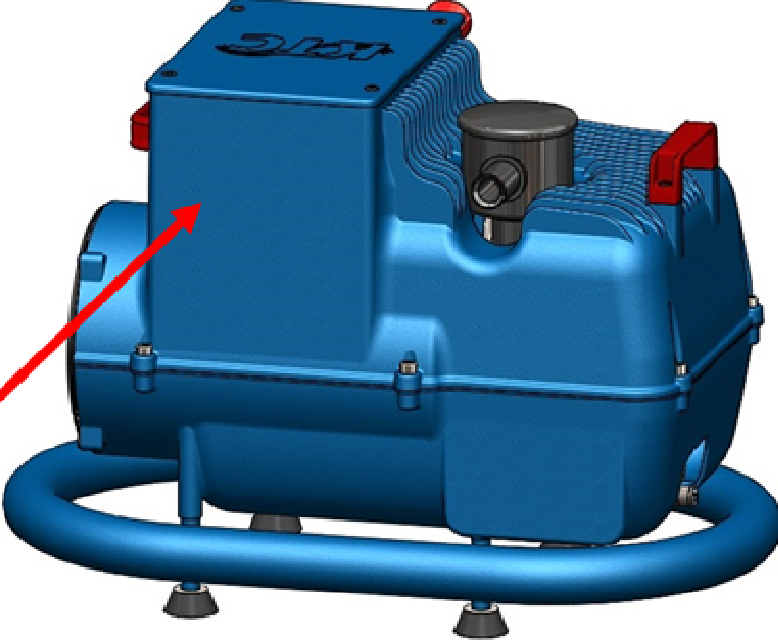

CE MARKING LABEL	
MODEL	COMPACT 2 SP
PART N°	180012039-03-001
SERIAL N°	AK100008774
MAX WORKING PRESS.	145 psi
POWER SUPPLY	230V / 1 / 60 Hz
NOMINAL POWER	4,1 hp
WEIGHT	99 lbs
YEAR MANUFACTURE	2018

### 3 CAUTIONS AND SAFETY WARNINGS



Read this operation manual carefully before performing any operations. Non-compliance with the instructions contained herein can lead to injury and property damage.

- The machine has been designed and built to operate as reported below. Any other use is considered unacceptable.
- Only qualified personnel can install and service the machine. Always follow accident prevention standards.
- The manufacturer is relieved of any responsibility for injuries and machine or property damage caused by incorrect use of the compressor, non-compliance or inadequate compliance with the safety criteria reported herein, modifications (even minor modifications) and by use of not original spare parts.

#### 3.1 INSTRUCTIONS FOR SAFE OPERATION



##### **CAUTION!**

**Below is a list of important instructions for safe use of the compressor. Follow these instructions carefully. Improper use or maintenance of the compressor can cause user injury.**

##### **1. Never Touch any Moving Parts**

Never allow parts of the body to come near moving parts of the machine.

##### **2. Never Use the Compressor if the Protection Guards have been Removed**

Never use the compressor unless all guards are assembled. If maintenance requires removing any of the guards, make sure that they are properly reinstalled before starting up the unit. Never bypass the safety devices installed on the compressor. This is strictly forbidden.

##### **3. Protective Grids**

Never insert objects or body parts into protective grids as this can cause injury and can damage the compressor.

##### **4. Use the Compressor Correctly**

Always operate the compressor following the instructions given in this manual. Never allow children or unauthorized persons to use the machine.

##### **5. Always Wear Eye Protection**

Always wear goggles or other equivalent form of eye protection. Do not direct air toward parts of the body, your own or others.

##### **6. Work Clothing**

Do not wear inappropriate clothing or accessories. If necessary, wear a cap that covers the hair.

##### **7. Use the Compressor Sensibly**

Never use the compressor while under the effect of alcohol, drugs or medications that can cause drowsiness.

## **8. Personnel Intervention**

Before performing any form of intervention, the personnel must be aware of all compressor functions and controls.

## **9. Compressor Usage**

Never use the compressor for any purpose other than those specified in the user's manual.

## **10. Air Jets**

Never direct air jet toward persons or animals.

## **11. Hot Parts**

To prevent burns, never touch the hoses, motor or other hot parts.

## **12. Work Area**

Keep the compressor work area clean and well ventilated. Never use the compressor in a place containing paints, solvents or combustible/explosive materials.

## **13. Compressor Maintenance**

Check the outside of the compressor. If the power supply cord is damaged, repair or replace it. If necessary, contact an Authorized Service Centre.

## **14. Check for Defective Parts and Air Leaks**

Check alignment of moving parts, hoses, pressure gauges, pressure reducers, pneumatic connections or other parts important to compressor function. Make certain that all screws, bolts and lids are thoroughly secured. Any damaged parts must be repaired by an Authorized Service Centre.

## **15. Protect yourself against Thermal Shocks**

Prevent accidentally coming into contact with metal parts of the compressor such as hoses, tanks or grounded parts. Never use the compressor if water or moisture is present in the area.

## **16. Disconnect the Compressor**

When servicing the compressor or when it is not running, always disconnect it from the power supply and completely vent the pressure in the tank.

## **17. Handling**

Never move the compressor while it is connected to the power supply or when the tank is pressurized. Before unplugging the compressor make certain that the switch is set to OFF.

## **18. Precautions for the Power Supply Cord**

Never unplug the unit by pulling on the cord. Never step on or crush the power supply cord. Keep it away from heat, oil or sharp surfaces. Never turn off the compressor by pulling on the power supply cord. Use the red emergency button to stop the compressor.

## **19. Electrical Extension Cords**

If the compressor is used outdoor, use power supply cords rated for outdoor use.

## **20. Cleaning of the Intake Grid and Plastic Parts**

Keep the ventilation grid clean. If the unit is used in a particularly dirty environment, clean the grid regularly. Never use solvents, thinners or other substances containing hydrocarbons as they can damage the plastic parts. Clean with soapy water or an appropriate liquid cleaner.

## **21. Compressor Rated Voltage**

Use the compressor at the voltage indicated on the label. Using the compressor at a different voltage can burn out or damage the electric motor.

## **22. Compressor Defects**

If the compressor makes strange noises or vibrates excessively during operations, check that it is functioning properly and, if necessary, contact an Authorized Service Centre.

## **23. Spare Parts**

Use only original spare parts which can be purchased from our distributors. Use of not original spare parts voids the warranty and can lead to compressor malfunction. Repairs must be carried out by an Authorized Service Centre.

## **24. Pneumatic Circuit**

Use hoses, connections and pneumatic tools rated to handle pressures above the operating pressure.

## **25. Tank**

Never unscrew any tank connections without first checking to ensure that the pressure has been vented. Never make holes, welds or modifications on the tank.

## **26. Compressor Modifications**

Never make any unauthorized modifications to the compressor. Such modifications can cause damage and serious injury. Consult an Authorized Service Centre for any operations.

## **27. Using the Compressor for Painting**

Never use the compressor in confined spaces or near open flames. Make certain that the work area is adequately ventilated. In addition, wear a special mask to protect nose and mouth.

## **28. Keep the Compressor Horizontal**

To ensure correct functioning of the compressor, it is advisable to work in a near-to horizontal position.



**KEEP THIS MANUAL INTACT AND ON HAND, AVAILABLE TO ANYONE USING THE COMPRESSOR!**



**WE RESERVE THE RIGHT TO MAKE ANY MODIFICATIONS DEEMED NECESSARY WITHOUT PRIOR NOTICE!**

### 3.2 CONTACTS AND USEFUL ADDRESSES

Our technical services department is at your disposal, ready to provide any information you may need and to help you resolve any problems that may arise.

For any information, please log onto our website [www.italyco.net](http://www.italyco.net)

For any clarifications you may require, contact our **customer services department** or your area **retailer**.

**Only original spare parts** can guarantee best performance of our compressors.

We recommend carefully following the instructions given in the chapter on **maintenance** and **always use only original spare parts**.

**Using not original parts automatically voids the warranty.**

## 4 DESCRIPTION OF THE MACHINE AND OPERATING PRINCIPLE

### 4.1 MACHINE DESCRIPTION

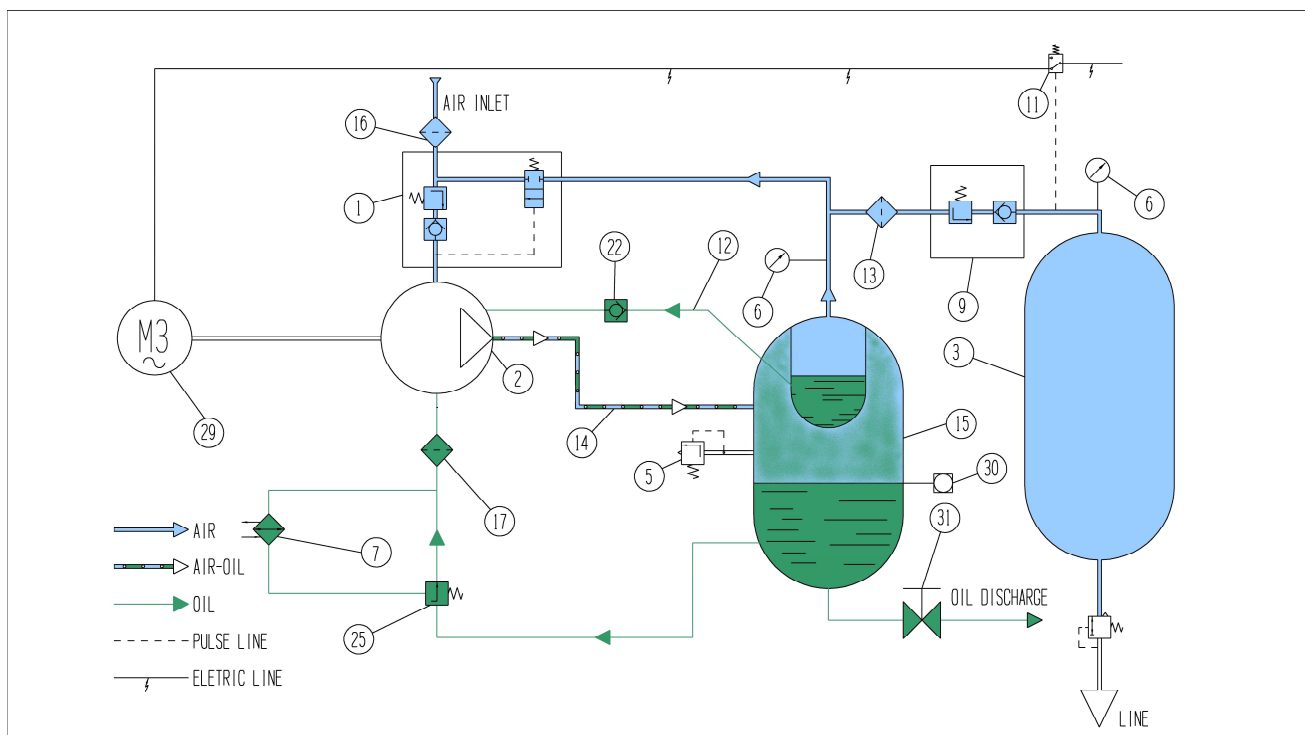

1	Suction valve
2	Screw compressor
3	Air tank (if present)
5	Pressure relief safety valve
6	Manometer
7	Oil radiator
9	Minimum pressure valve
11	Pressure switch / Pressure transmitter
12	Oil return from separator
13	Oil separator filter
14	Air/oil delivery hose from screw assembly
15	Air/oil separator tank
16	Suction filter
17	Oil filter
22	Oil recovery window
25	Thermostatic valve
29	Electric motor
30	Oil level
31	Oil discharge

## 4.2 OPERATING PRINCIPLE

- During the initial phase (unload), the electric motor ref. 29 reach the set operating RPM. The solenoid valve is not powered and thus the suction valve ref. 1 remains closed. The length of this phase can be set.
- During the second phase (load), the solenoid valve is powered and the suction valve ref. 1 is opened, thus allowing air to pass through the suction filter ref. 16 and enter the screw compressor ref. 2. This starts the compression phase.
- The air/oil mixture delivered by the screw compressor ref. 2 is conveyed into the air/oil separator tank ref. 15.
- An initial portion of the oil is separated from the air mechanically and deposits at the bottom of the tank while the air collects at the top.
- By force of pressure the air is forced to flow through the oil separator filter ref. 13 and, after further separation of the oil, it is sent on to the minimum pressure valve ref. 9. This allows passage of the air only after the pressure set point has been reached. When this happens, the air passes through the air tank ref. 3 (if present).  
The oil removed from the air inside the oil separator filter is sent, through the oil return from separator line ref. 12, into the screw compressor. The amount of oil can be monitored through oil recovery window ref. 22.
- The pressure sends oil at the bottom of the tank to the thermostatic valve ref. 25. This valve sends the oil with a temperature above the set point to the oil radiator ref. 7 where it is cooled. Once cooled, the oil returns to the thermostatic valve, is mixed with hot oil coming from the tank and is again checked by the thermostatic valve. Once the temperature set point (low) is exceeded, the oil is sent to the oil filter ref. 17 and then into the screw compressor.
- When the set maximum working pressure is reached, the pressure switch ref. 11 remove power from the solenoid valve and trips the circuit. The suction valve ref. 1 closes air flow and the compressor enters in "unload" operating mode. This situation remains in force until the system minimum pressure setting is reached.  
If consumption is low or has stopped unit will continue operate in no-load mode for a set amount of time and then reverts to stand-by mode.
- The condensate that accumulates inside the tank must be discharged daily through the special drain in the lower part of the tank.

## 5 DATA AND TECHNICAL SPECIFICATION

Model	KV 3	
Machine type	Oil injected screw compressor	
Drive	Direct drive	
Type of screw	ADAM V50	ADAM V50
Type of fluid handled	Air	Air
Flow rate (ISO 1217:2009 annex C)**	0,27 m <sup>3</sup> /min – 9,5 cfm	0,311 m <sup>3</sup> /min – 10,9 cfm
Max. working pressure	10 bar g - 145 psi g	8 bar g - 116 psi g
Min. working pressure	5 bar g – 72,5 psi g	5 bar g – 72,5 psi g
Maximum power consumption**	2,7 kW – 3,6 hp	2,7 kW – 3,6 hp
Max. air/oil outlet temperature	105 °C - 221°F	105 °C - 221°F
Max. environmental temperature	45 °C - 113 °F	45 °C - 113 °F
Min. environmental temperature*	5 °C - 41 °F	5 °C - 41 °F
Weight	40 kg – 88 lb 46 kg – 101,4 lb (2,5 lt) 52 kg – 114,6 lb (trolley) 78 kg – 172 lb (90lt)	40 kg – 88 lb 46 kg – 101,4 lb (2,5 lt) 52 kg – 114,6 lb (trolley) 78 kg – 172 lb (90lt)
Power supply voltage	<b>230V/1ph/50Hz</b>	<b>230V/1ph/60Hz</b>
Max. current consumption**	14,5 A	17 A
Electric motor protection rating	IP 54	IP 54
Insulation class	F	F
Service factor	S1	S1
Oil charge	1 lt – 0,264 U.S. gal	1 lt – 0,264 U.S. gal
Air outlet connection	1/4”	1/4”
Oil residue in air	< 5 ppm	< 5 ppm
Electric motor	MEC90	MEC90
Noise level***	< 65 dB(A)***	< 65 dB(A)***

\* When the environmental temperature is below 5°C, an ISO VG 32 lubricant must be used

\*\* Value detected with the respective max working pressure

\*\*\* Noise measured in an open field at 1 metre from the unit ±3 dB(A) at maximum working pressure



<b>Model</b>	<b>KV 4</b>		
<b>Machine type</b>	Oil injected screw compressor		
<b>Drive</b>	Direct drive		
<b>Type of screw</b>	ADAM V60	ADAM V60	ADAM V60
<b>Type of fluid handled</b>	Air	Air	Air
<b>Flow rate (ISO 1217:2009 annex C)**</b>	0,311 m <sup>3</sup> /min – 10,9 cfm	0,29 m <sup>3</sup> /min – 10,2 cfm	0,38 m <sup>3</sup> /min – 13,4 cfm
<b>Max. working pressure</b>	10 bar g - 145 psi g	10 bar g - 145 psi g	10 bar g - 145 psi g
<b>Min. working pressure</b>	5 bar g – 72,5 psi g	5 bar g – 72,5 psi g	5 bar g – 72,5 psi g
<b>Maximum power consumption**</b>	3,6 kW – 4 hp	3 kW – 4 hp	3,6 kW – 4 hp
<b>Max. air/oil outlet temperature</b>	105 °C - 221°F	105 °C - 221°F	105 °C - 221°F
<b>Max. environmental temperature</b>	45 °C - 113 °F	45 °C - 113 °F	45 °C - 113 °F
<b>Min. environmental temperature*</b>	5 °C - 41 °F	5 °C - 41 °F	5 °C - 41 °F
<b>Weight</b>	40 kg – 88 lb 46 kg – 101,4 lb (2,5 lt) 52 kg – 114,6 lb (trolley) 78 kg – 172 lb (90lt)	40 kg – 88 lb 46 kg – 101,4 lb (2,5 lt) 52 kg – 114,6 lb (trolley) 78 kg – 172 lb (90lt)	40 kg – 88 lb 46 kg – 101,4 lb (2,5 lt) 52 kg – 114,6 lb (trolley) 78 kg – 172 lb (90lt)
<b>Power supply voltage</b>	<b>230V/1ph/60Hz</b>	<b>400V/3ph/50Hz</b>	<b>230V-460/3ph/60Hz</b>
<b>Max. current consumption**</b>	17,3 A	5,8 A	11,5 A (230V) – 7 A (460V)
<b>Electric motor protection rating</b>	IP 54	IP 54	IP 54
<b>Insulation class</b>	F	F	F
<b>Service factor</b>	S1	S1	S1
<b>Oil charge</b>	1,3 lt - 0.343 U.S. gal	1,3 lt - 0.343 U.S. gal	1,3 lt - 0.343 U.S. gal
<b>Air outlet connection</b>	1/4”	1/4”	1/4”
<b>Oil residue in air</b>	< 5 ppm	< 5 ppm	< 5 ppm
<b>Electric motor</b>	MEC100	MEC90	MEC90
<b>Noise level***</b>	< 65 dB(A)***	< 65 dB(A)***	< 65 dB(A)***

\* When the environmental temperature is below 5°C, an ISO VG 32 lubricant must be used

\*\* Value detected with the respective max working pressure

\*\*\* Noise measured in an open field at 1 metre from the unit ±3 dB(A) at maximum working pressure

## 6 DIMENSIONS

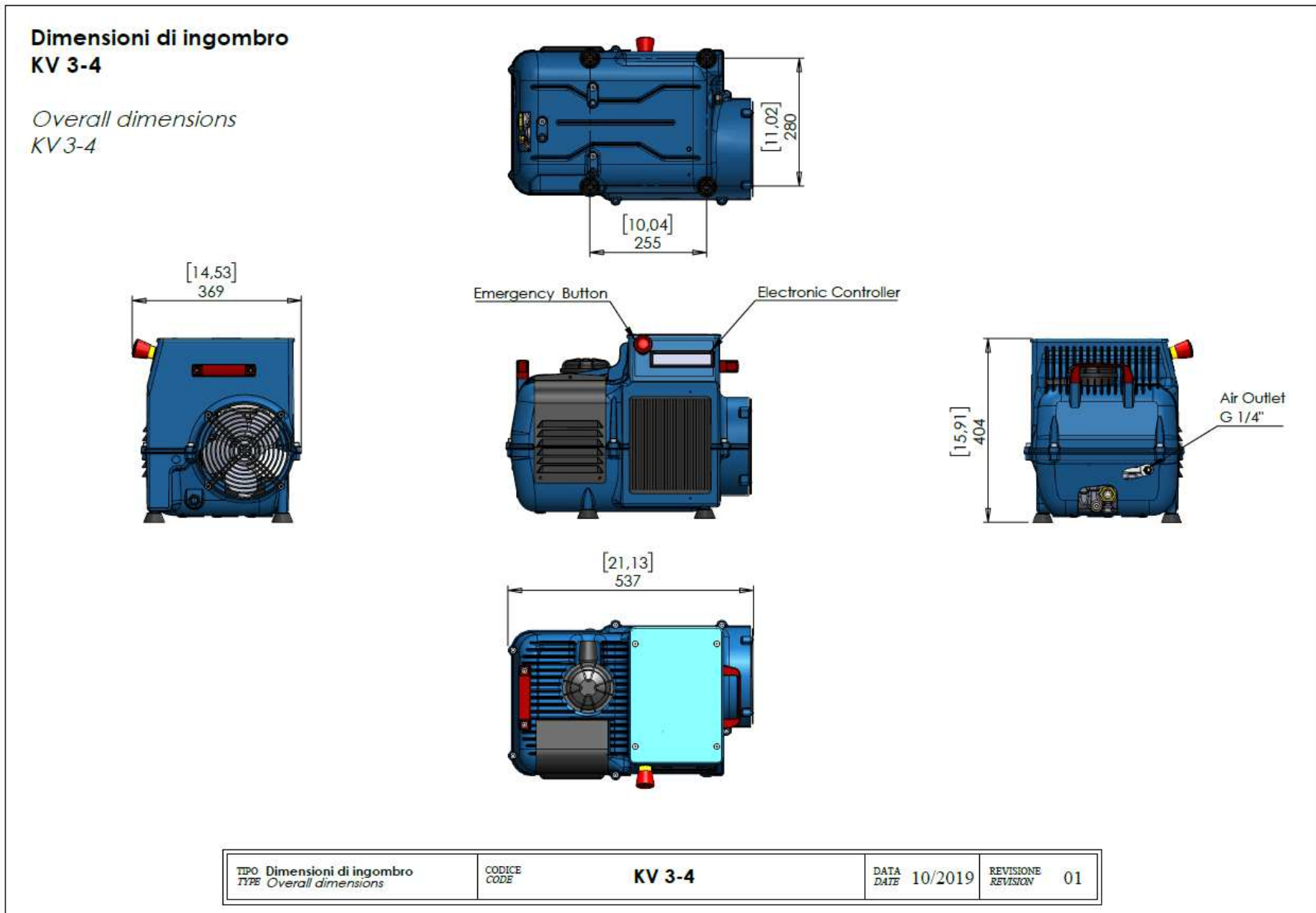

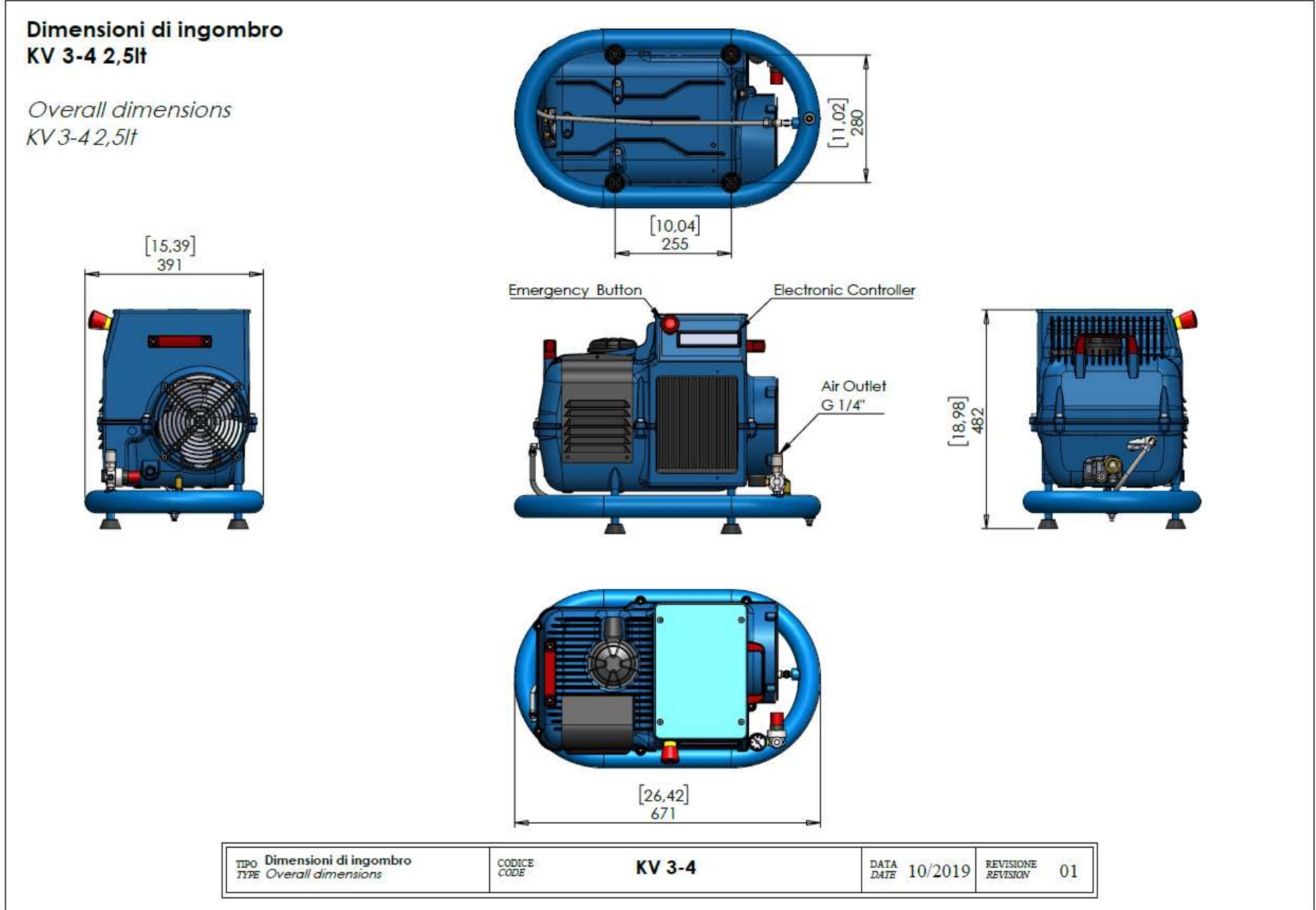

**Dimensioni di ingombro**  
**KV 3-4 2,5lt trolley**

*Overall dimensions*  
*KV 3-4 2,5lt trolley*

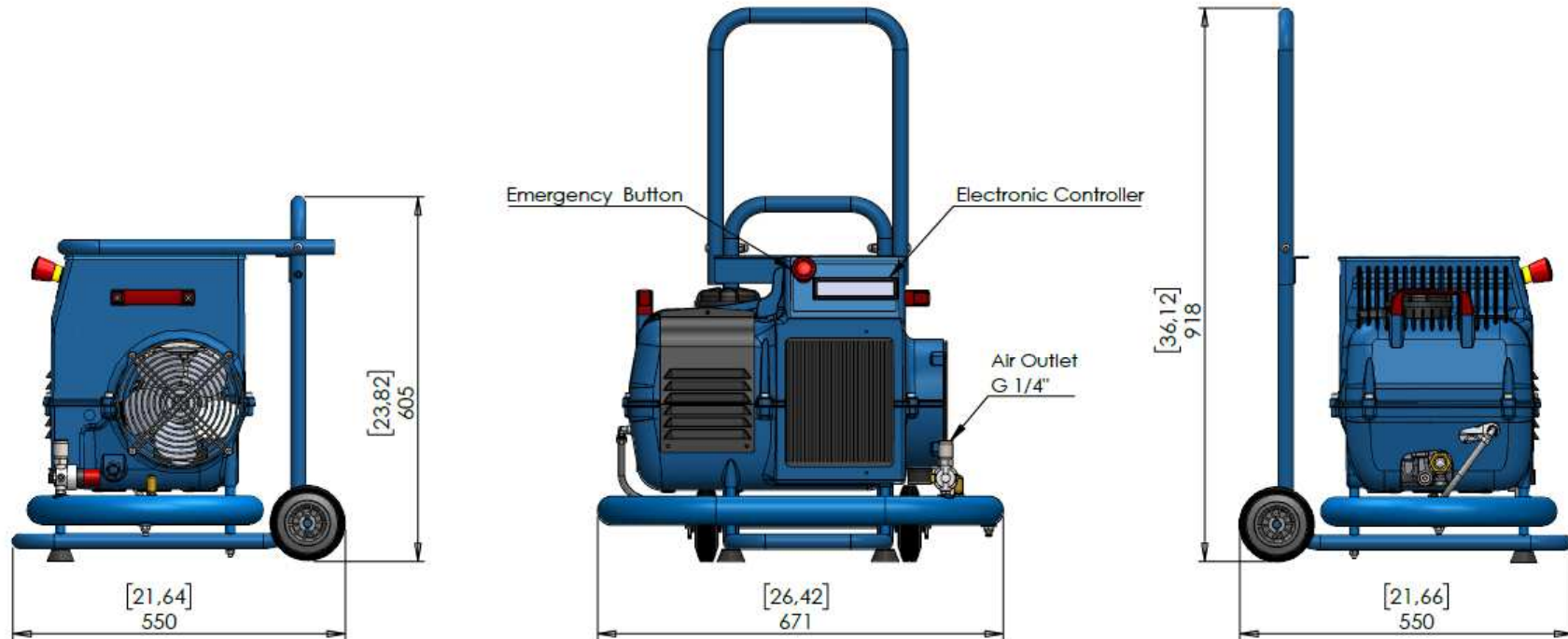

TIPO <b>Dimensioni di ingombro</b> TYPE <i>Overall dimensions</i>	CODICE <b>KV 3-4</b> CODE	DATA <b>10/2019</b> DATE	REVISIONE <b>01</b> REVISION
--	------------------------------	-----------------------------	---------------------------------

**Dimensioni di ingombro**  
**KV 3-4 90lt**

*Overall dimensions*  
*KV3-4 90lt*

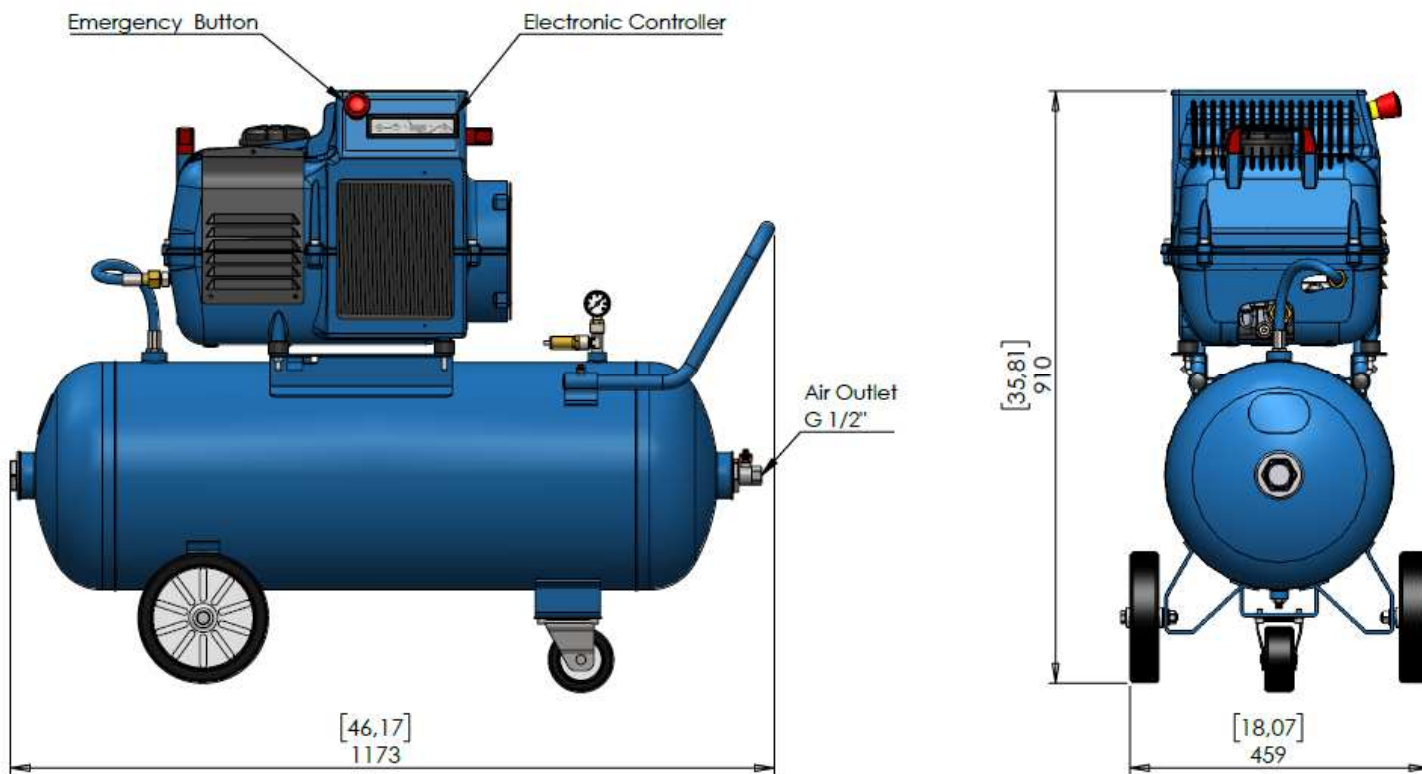

TIPO TYPE	Dimensioni di ingombro Overall dimensions	CODICE CODE	<b>KV 3-4</b>	DATA DATE	10/2019	REVISIONE REVISION	01
--------------	--	----------------	---------------	--------------	---------	-----------------------	----

## 7 INSTALLATION



### 7.1 CHARACTERISTICS AND STORAGE CONDITIONS

During periods of inactivity, before being unpacked (storage), the compressor must be kept at a temperature of between +5°C - 41°F and +45°C - 113°F.

If the compressor has remained inactive for a long period of time, before starting it up again, change the oil and check function.

### 7.2 TRANSPORT

To ensure that the unit is protected and does not incur shipping damages, the compressor is covered with a cardboard box.

All shipping information is printed on the compressor package (data and pictograms).

### 7.3 UNPACKING

When unpacking the unit, carefully check that the contents match what is indicated in the shipping documents.



**The user must dispose of packaging in compliance with current national regulations.  
The machine must be unpacked by qualified personnel using suitable tools.**

## 7.4 HANDLING

- Check that the outside packaging is intact.
- Unpack the machine carefully.
- Check that the outside of the machine is intact.
- Dispose of the packaging in compliance with current environmental regulations.

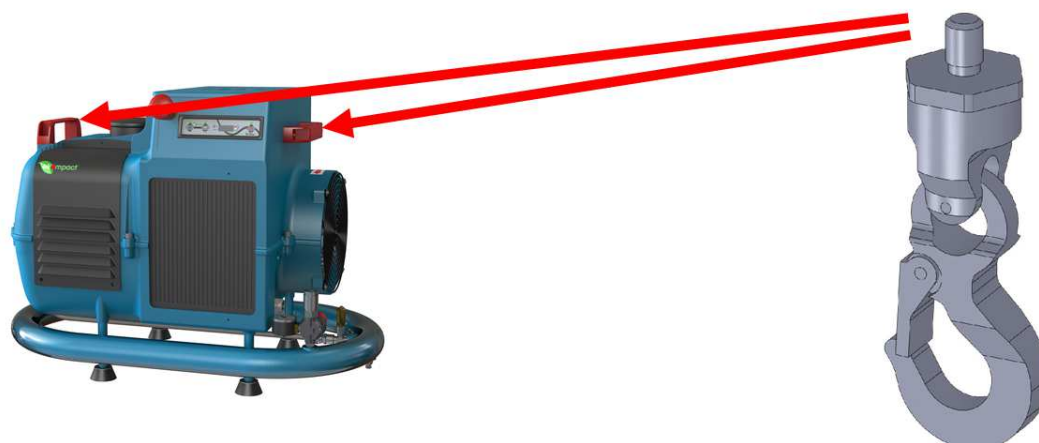

**Figure 4**

Use lifting hooks for compressor moving (see figure 4).

## 7.5 LOCATION



Install the compressor at the site point indicated at the time the order was placed. If the unit is installed at a different site, **the manufacturer cannot be held responsible for any ensuing problems.**

Unless specified otherwise at the time the order is placed, the compressor must run normally under the environmental conditions indicated below.

The room where the compressor is installed must comply with current accident prevention standards and must meet the following requirements:

- The unit must be positioned on a horizontal surface and resting on the respective anti-vibration mountings. Under no circumstances should the compressor be tilted during operation.
- Adequately ventilated and of such size that environmental temperature remains steady (min. +5°C - 41°F, max. +45°C - 113°F) when the machine is running. At the maximum admissible environmental temperature (45°C - 113°F) and with a relative humidity above 80% machine performance can reduce. Likewise, machine performance may be reduced when the unit is installed at an altitude of 1000 m above sea level.
- Lighting: the compressor is built considering current standards and seeking to reduce shadow zones to the barest minimum, thus facilitating operator intervention; as the compressor room lighting system is deemed important for personnel safety, there must not be any shadows, glaring lights or stroboscopic effects due to the lighting.
- Potentially explosive and/or flammable atmospheres: in its standard configuration, the compressor **is not designed to work in environments where there is the risk of explosion and/or fire.**

## 7.6 CONNECTION AND START-UP



### 7.6.1 GENERAL WARNINGS

When starting up the unit for the first time, make certain that:

- The power supply matches the requirements indicated on the label.
- The wall-mounted general switch is proportioned according to the indications in the technical data table (see chapter 7.6.2.1).
- The oil is at the correct level (see chapter 10.4).
- The electrical connections have been made using cables of adequate section (see chapter 7.6.2.3)

#### **CAUTION!**



**Carefully comply with the SAFETY WARNINGS regarding use of the machine.**



**For the European market the compressors and tanks are built according to the Directives in force mentioned in the declaration of conformity attached to the machine**



**Check the label on the compressor and at the beginning of this manual for indication of your model.**



## 7.6.2 ELECTRICAL CONNECTION OF COMPRESSOR



The electrical connection to the electrical line is carried out by the end user. He bears the costs and responsibility for quality and compliance standards, which must be performed by trained personnel in accordance with accident prevention regulations EN 60204.

### 7.6.2.1 FUSE AND BREAKER



It is recommended to install the connector, the circuit breaker and fuses near the compressor (not more than 3 metres – 118,11in away). The circuit breaker and the fuses must have the characteristics shown in the following table:

- The voltage (volts) must correspond to that indicated on the nameplate of the electrical machine; tolerance must be within the + / -5%.
- The plug of the power cable should not be used as a switch. Do not remove power while unit is running; for emergency action to switch of the compressor or on the appropriate line switch (breaker), see table.

KW/HP	Voltage	Magnetothermic Curve “ D “	Fuse with delay
2,7 / 3,6	230V/ 1/50-60HZ(8bar)	25 A	25 aM
3 / 4.1	230V/1/60HZ (10bar)	32 A	32 aM
3 / 4,1	400V-460V/ 3/ 50-60HZ	16 A	12 aM
3 / 4,1	230V-460V/ 3/60HZ	20 A (230V)/ 16 A (460V)	16 aM (230V)/ 12 aM (460V)



Never use the ground instead of neutral. The ground connection must be made in accordance with safety regulations (EN 60204). Verify that the mains voltage corresponds to that required for the proper functioning of the compressor.

### 7.6.2.2 GROUND CONNECTION

The compressor must be connected to the ground during its use, in order to protect the operator from accidental electric shocks. It's necessary that the connections are made by a technician or an authorized service center. The grounding conductor yellow / green wire of the power of the compressor must only be connected to terminal of the compressor. The ground wire connected to a facility must be properly equipped with mandatory safety switch.

### 7.6.2.3 SIZING OF ELECTRIC CABLE

Do not use a damaged cable but make sure it is in good condition. This section must be appropriate to the current requested by the compressor. A little section of power cable can cause a voltage drop with consequent loss of power and excessive heating of the cable itself, which can cause irreparable consequences on the device supply. The cable section must be in proportion to its length. For variations and modifications contact a qualified service centre.

<b>KW / HP</b>	<b>Voltage</b>	<b>SIZING</b>
<b>2,7 / 3,6</b>	230V/ 1/50-60HZ(8bar)	<b>2,5 mm<sup>2</sup> / AWG 14</b>
<b>3 / 4.1</b>	230V /1/60HZ (10bar)	<b>2,5 mm<sup>2</sup> / AWG 14</b>
<b>3 / 4,1</b>	400V-460V/ 3/50-60HZ	<b>1,5 mm<sup>2</sup> / AWG 16</b>
<b>3 / 4,1</b>	230V-460V/ 3/60HZ	<b>1,5 mm<sup>2</sup> / AWG 16</b>



**Avoid any risk of electric shock. Never use the compressor with a damaged power cable. It is recommended to be checked periodically by a qualified power cords. Never use the compressor in areas where they can be hazardous leakage current.**



**All electrical installations and maintenance on facility must be performed by a qualified technician.**

### 7.6.3 WIRING DIAGRAM

The specific scheme of the machine is contained in the specific box.

### 7.6.4 AIR CIRCUIT CONNECTION



**Make certain that the compressed air hoses used have adequate maximum pressure rating and section for the compressor. Never repair defective hoses; they must always be replaced.**

Connect the compressor to the pneumatic mains system, using the special female connection as indicated in the overall dimensions section (chap.6)

### 7.7 FIRST START-UP



The first compressor start up (operational testing) must be performed by a qualified technician. Remember, for the technical warranty to be valid, that the registered test report (R.C.R.) attached to the documentation must be filled out (see notes on sales clauses).

After having followed all the indications contained in the previous chapters, it is possible to proceed with the preparation of the machine for the first start-up.

For the three-phase version, is present in the compressor a control device which ensures the correct rotation of the screw unit each time the compressor starts.

If the supply phases are correctly positioned the compressor will start as indicated on the arrow on the body of the screw and as shown in Picture 10.



**This control must be carried out making performing a start with an immediate shutdown and checking that the electric motor fan turns in the same direction of the arrow placed over the screw (three-phase version only).**

If the phases of the supply line are positioned incorrectly, the compressor does not start. Swap the connections of two phases of power line and restart the compressor.

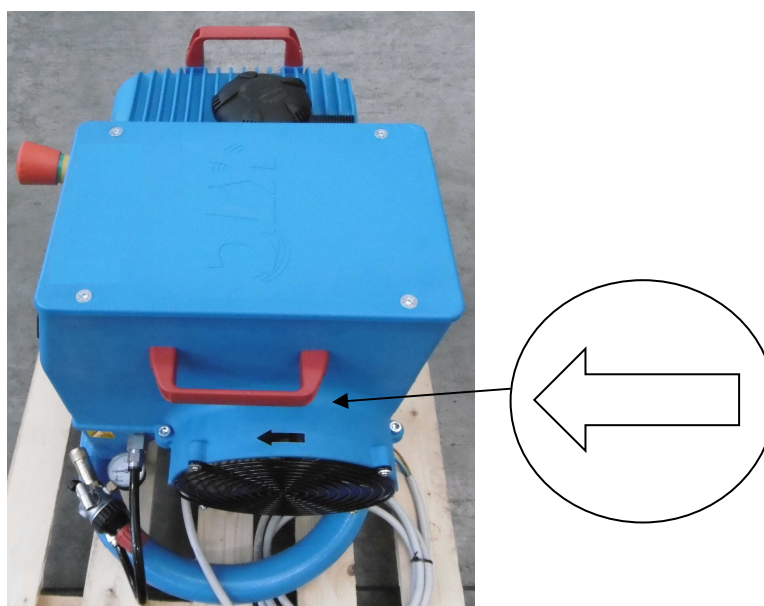

Picture 10



**The reverse rotation of the screw from the direction of the arrow shown on the body may damage the screw!**



**In case of replacement of the electric motor, at the time of restart is absolutely necessary to visually check the direction of rotation of the screw unit.**



**It's absolutely necessary to strictly follow the SAFETY PRECAUTIONS on the use of the machine.**



**CAUTION!**

**Always carefully follow the SAFETY WARNINGS regarding use of the machine. This is extremely important.**

## **7.8 CLEANING AND DISINFECTION**



Keeping the installation site and the compressor clean is essential to good machine operation and keeps operating and maintenance costs down.

Installation site and compressor disinfection is essential to guarantee good air quality in the compressor room and in the area where the compressed air is used (workshop).

## **7.9 REINSTALLATION AND REUSE**

Reinstallation and reuse of the machine must be performed by qualified personnel and only after checking the condition of the machine itself.

The points indicated in the previous chapters hold here as well.

## **7.10 DEMOLITION AND DISPOSAL**



If the compressor is to be demolished and disposed of, this must be performed in compliance with current regulations.

Always contact an authorized waste disposal and recycling facility.

## 8 OPERATION AND USE

### 8.1 DESCRIPTION OF THE OPERATION

For the machine functions, see chap. 4.

### 8.2 RANGE OF APPLICATIONS

The machine is suited to all those applications requiring compressed air at the flow rate and pressure outlined in the technical data sheet (see chap. 5).

### 8.3 PROPER AND IMPROPER USE

#### CAUTION!



**The compressor is designed and built solely to produce compressed air. The manufacturer is relieved of any responsibility for risks ensuing from any other use.**

#### CAUTION!



**Any use of the compressor that differs from the agreements made at the time of purchase relieves the manufacturer of any responsibility for ensuing injury or property damage or damage to the machine itself.**

#### CAUTION!



**The electrical system cannot be used in flame-proof areas and with flammable products.**

#### CAUTION!



**Never direct air jet toward persons or animals. Never use compressed air for breathing or in production processes where the air produced is in direct contact with foodstuffs, unless previously treated and filtered.**

### 8.4 OPERATING AND ENVIRONMENTAL LIMITS

The operating and environmental limits are indicated in the table containing the technical data and characteristics (see chap.5).

### 8.5 WORKSTATION AND DANGEROUS AREAS







During normal operation of the machine, the operator works on the side where the electronic controller / ignition switch is located. Once correctly connected to the electrical and pneumatic system, the machine is completely protected on the outside and thus there are no dangerous areas accessible during normal operation.

When scheduled and unscheduled maintenance is performed, the machine is completely open. These operations must be performed under safe conditions by qualified personnel.

## 8.6 SAFETY DEVICES AND SIGNALS

The machine is equipped with safety devices and signals to prevent situations dangerous for the operator and the machine itself.

These devices and signals come in the form of labels placed at dangerous points, and alarms that are displayed on the electronic controller.

SIGNAL	MEANING
	<p><b>ATTENTION:</b>  <b>Do not perform any maintenance operations on this machine before:</b></p> <ul style="list-style-type: none"> <li>• having stopped all moving parts</li> <li>• have disconnected the power supply</li> <li>• have completely discharged the pressurized air.</li> <li>• Maintenance and repair must be performed by specialized and authorized personnel!</li> <li>• Never incline the compressor</li> </ul>
	<p><b>ATTENTION:</b>  <b>Hot surface</b></p>
	<p><b>ATTENTION:</b>  <b>Component or pressurized system</b></p>
	<p><b>ATTENTION:</b>  <b>Risk of electric shock</b></p>
	<p><b>ATTENTION:</b>  <b>Drain condensation</b></p>
	<p><b>ATTENTION:</b>  <b>Check the oil level with the machine stopped</b></p>
	<p><b>ATTENTION:</b>  <b>See the instruction book for the maintenance</b></p>

### 8.6.1 POSITION OF THE LABELS

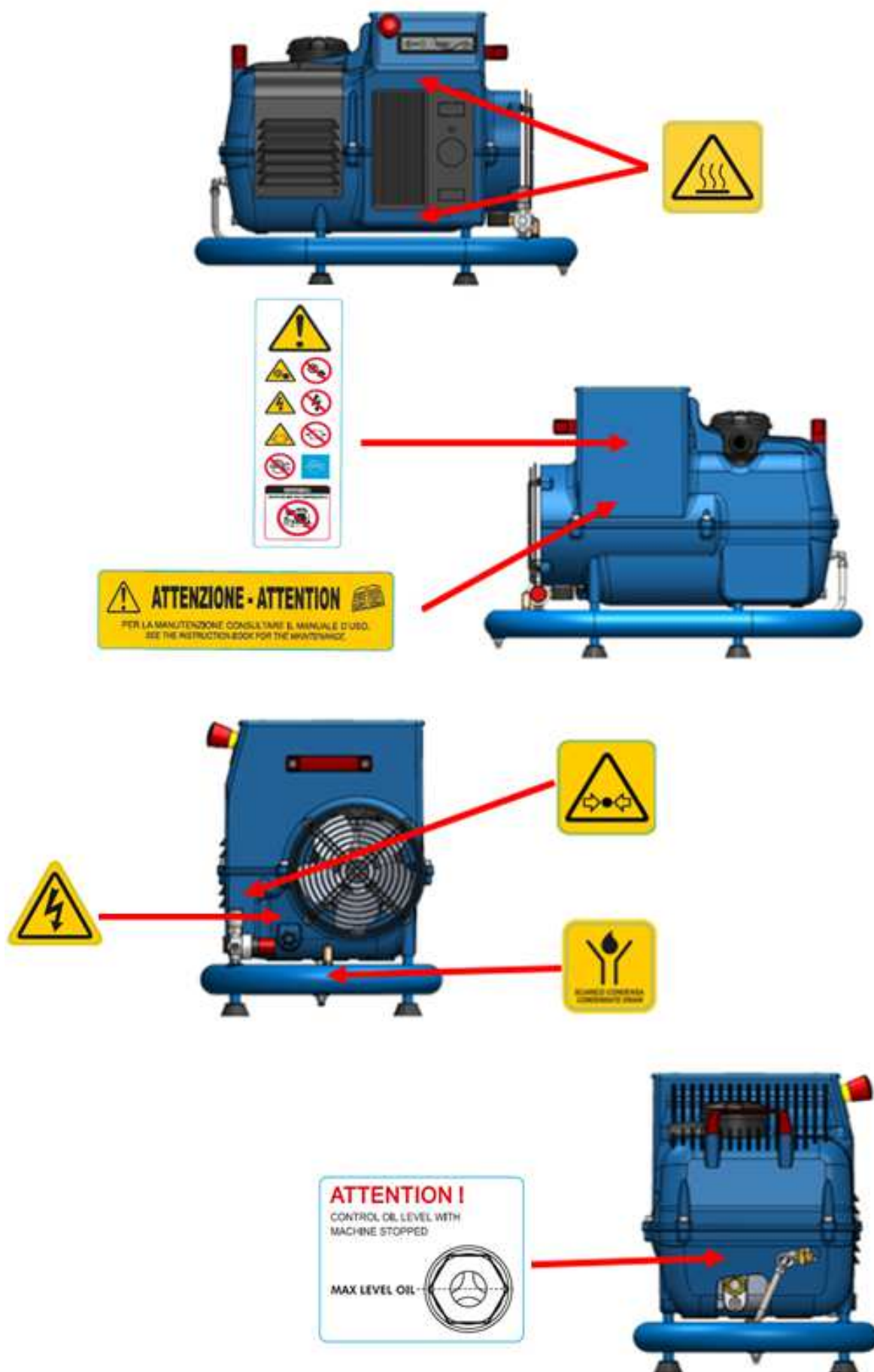

## 8.7 COMPRESSOR LUBRICATION



### 8.7.1 GENERAL RECOMMENDATIONS

#### CAUTION!



Before performing any operation involving draining or topping up compressor oil, unplug the compressor and wait until the system has reached atmospheric pressure.

Use adequate protection when handling lubricants.

We recommend a lubricant compatible with the ISO VG 46 oil (mineral-based oil) used during testing. The pour point must be at least  $-8+10^{\circ}\text{C}$  and the flash point higher than  $+200^{\circ}\text{C}$ .

### *Oilscrew plus 46*

For use of incompatible oils, follow the procedure described in chapter 8.8



**Never mix different types of oil**

We recommend using oil with a VG32 ( $-10^{\circ}\text{C} - 50^{\circ}\text{F} / 0^{\circ}\text{C} - 32^{\circ}\text{F}$ ) rating for cold climates and VG68 for tropical climates ( $+20^{\circ}\text{C} - 68^{\circ}\text{F} / +50^{\circ}\text{C} - 122^{\circ}\text{F}$ ).

Before starting up compressors without oil, feed **approximately 0.1 lt - 0.0264 U.S. gal** of lubricant in through the regulator intake opening while keeping the suction valve shutter lowered and manually turning the screw rotors in the right direction.



#### CAUTION!

**When lowering the suction valve shutter be careful not to damage the throttle valve O-ring.**

- Feed the mineral-based lubricant into the oil tank using the special top-up hole and fill until the right level is read on the window.



- Start up the compressor, initially switching it on and off sequentially and quickly and then starting it up.



- Once initially filled with oil, turn off the compressor, vent the pressure and, if necessary, top up the lubricant from the top-up hole until the right level is read on the window.





## 8.8 USING THE COMPRESSOR WITH SYNTHETIC OILS



If you wish to use a synthetic lubricant, carefully follow the procedure below.

- Drain all mineral oil from the compressor circuit using the oil drain ball valve.



- Feed the synthetic lubricant or detergent oil into the oil tank through the top-up hole and fill up to the correct level.



- Before starting up the compressor or the first time after installation, feed **approximately 0.1 lt - 0.0264 U.S. gal** of lubricant in through the regulator intake opening while keeping the suction valve shutter lowered and manually turning the screw rotors in the right direction.



### CAUTION!

**When lowering the suction valve shutter be careful not to damage the throttle valve O-ring.**

- Start up the compressor, initially switching it on and off sequentially and quickly and then starting it up.
- Then turn off the compressor and drain all lubricant from the system using the ball valve.



- Through the oil top-up hole, feed new synthetic lubricant in until it reaches the set level; then start up the compressor and run it steady for about 10 minutes.



- Turn off the compressor, vent the pressure and, if necessary, top up by feeding the lubricant through the top-up hole until the right level is read on the window.



### CAUTION!



**If the above-mentioned “washing” cycle is not performed, the mixing of incompatible lubricants may cause problems in lubrication. Use adequate protection when handling lubricants.**

**Dispose of mineral lubricants in compliance with current environmental regulations.**

### CAUTION!



**Before carrying out any oil extraction or topping up on the compressor, disconnect the power supply and wait for the pressure inside the oil separator tank to be 0 bar/PSI.**

**Use adequate protection when handling lubricants.**

## 9 INSTRUCTIONS FOR THE USER



### 9.1 DESCRIPTION OF THE CONTROL DEVICES

## ELECTRONIC CONTROLLER

# *Ktronic 5*

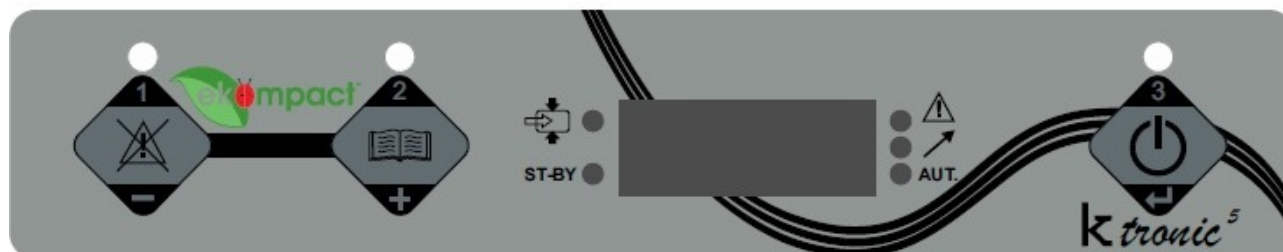

### 9.1.1 BUTTON LAYOUT



#### START STOP BUTTON

when pressed, this button starts and stops the compressor

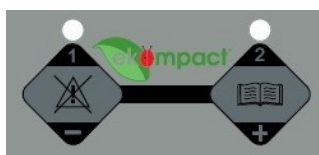

#### MENU' BUTTONS (1-2)

In programming mode, when pressed, those buttons change parameters values



#### BUTTON PROGRAMMING (1)

When pressed, it shows the total work hours.

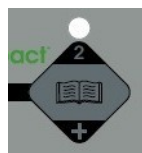

#### BUTTON PROGRAMMING (2)

With the compressor stopped, it is possible to view the parameter list.

In working mode, when pressed, it compares system temperature.



#### PARAMETER AND ALARM CHANGE BUTTON (3)

During the modification phase, a short press will confirm the value of the selected parameter.

In alarm mode, if pressed for more than 3 seconds, it resets the alarms.

## 9.1.2 SYMBOL LAYOUT

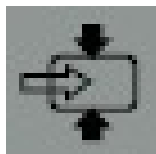

**LOAD SYMBOL**  
when LED is on, compressor is in load phase



**STAND BY SYMBOL**  
when led is on, compressor is in stand by phase

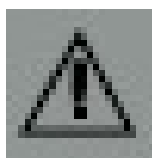

**ALARM SYMBOL**  
when led is on, compressor is in alarm state









**REMOTE CONTROL SYMBOL**  
when led is on, compressor is in remote control state

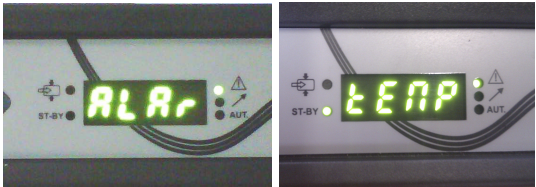

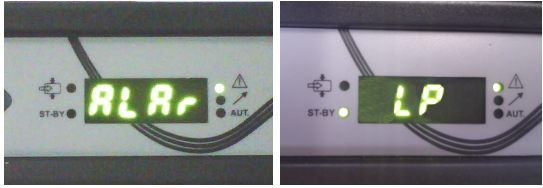
**AUTOMATIC RESTART SYMBOL**  
when led is on, compressor is in automatic restart state

## 9.2 ALARMS LIST

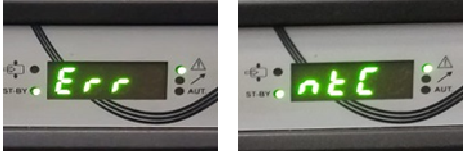
TYPE OF ALARM	CODE*	DESCRIPTION
 <p>" THERMAL ELECTRIC MOTOR"</p>	AL02	MAX TEMPERATURE OF THE ELECTRIC MOTOR EXCEEDED
 <p>"TEMPERATURE ALARM"</p>	AL05	MAX TEMPERATURE OF THE PUMPING GROUP EXCEEDED
 <p>"PRESSURE OVERLOAD"</p>	AL01	MAX SET PRESSURE EXCEEDED
 <p>"EMERGENCY OR WRONG ROTATION"</p>	AL03	EMERGENCY BUTTON PRESSED or WRONG TOWARD OF ROTATION OF THE ENGINE (reverse one of the 3 phases)
 <p>"MAINTENANCE ALARM"</p>	AL07	MAINTENANCE ALARM carry out maintenance if necessary and reset the maintenance hours with parameter P8 (inserting the protection key)

 <p><b>"TEMPERATURE PROBE ALARM"</b></p>	<p><b>AL06</b></p>	<p><b>READING ERROR OR WRONG TEMPERATURE PROBE CONNECTION.</b></p> <p><b>Check connection to terminals cn8: ntc of the controller.</b></p>
 <p><b>"PRESSURE PROBE ALARM"</b></p>	<p><b>AL04</b></p>	<p><b>READING ERROR OR WRONG CONNECTION OF THE PRESSURE PROBE.</b></p> <p><b>Check connection to terminals CN9: + V and AUX2 of the controller.</b></p>

**\*=Alphanumeric code present only in firmware release 34**

## 9.3 DESCRIPTION OF THE OPERATIONS TO BE PERFORMED

### 9.3.1 STARTING THE COMPRESSOR

When machine is powered it appears the following flashing screen:



for few seconds, then:



---

By pressing



it appears the following flashing screen:



for few seconds, then the machine start to load. It appears the value of system pressure.



By pressing



it appears the value of system temperature:



By pressing



it appears the flashing value of working hours:

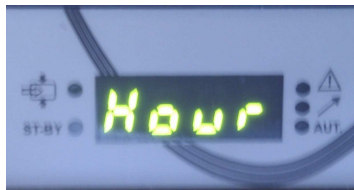



## 9.3.2 PROGRAMMING

With machine stopped, by pressing:



machine stopped it appear programmable parameters

---

By pressing



it is possible to change the parameter to modify

---

By pressing



the selected parameter can be changed

---

By pressing



it is possible to modify the selected parameter

---

By pressing



the changed parameter is confirmed

### 9.3.3 PARAMETER

PARAMETER	TYPE	DESCRIPTION	PRESET VALUE	RANGE	PASSWORD
P1	Stand-by time	After this time the unit enters in stand-by mode	30 sec	20÷600	NO
P2	System Temperature	Below this temperature, the unit doesn't turn off when the stand-by time is over.	50 °C 122 °F	10 °C ÷ 100°C 50 °F ÷ 212 °F	NO
P3	Max Temperature	At this temperature of the unit turns off and the display shows "Temperature Alarm"	100 °C (*) 212 °F (*)	10°C ÷ 170 °C 50 °F ÷ 338 °F	NO
P4	Fan temperature	Fan starting temperature (only in the presence of an electric fan)	60 °C 140 °F	1°C ÷ 120 °C 34 °F ÷ 248 °F	NO
P5	Working Pressure (Unloading)	At this pressure the unit closes the Inlet Valve and the blowdown starts (unloading/idling mode)	10 Bar 145 PSI	$6 \leq P5 \leq P12$	NO
P6	Loading Pressure	At this pressure the unit opens the Inlet Valve and starts to build air (loading mode)	1 Bar 14,5 PSI	0,5÷3 (Bar) 7,25÷43,5 (PSI)	NO
P7	Maintenance time	Maintenace required after this interval. The display shows "Maintenace alarm" after this interval	500 hours	1 ÷ 3000 hours	YES
P8	Maintenance reset	Resetting the maintenace alarm	---		YES
P9	Next maintenace	Shows the hours to the next maintenace	---		YES
P10	Star/Delta delay	Delay between the Star and Delta phases (3Ph units only)	20ms	RESERVED	YES

P11	Over Pressure Offset	The unit shows "Over Pressure Alarm" when the pressure reaches the Working Pressure (P5) + offset	1 BAR 14,5 PSI	RESERVED	YES
P12	Max Working Pressure	Max Working Pressure. It limits the parameter P5	10 BAR 145 PSI	RESERVED	YES
P13	Start counter	Shows the number of start cycles (1=100 starts)	---	00÷99	NO
P14	Idling counter	Shows the hours in unloading/idling mode	---	00÷99	NO
P15	BAR / PSI	Change from Metric to Imperial	BAR/°C	BAR/PSI - °C /°F	NO
P16	Drain discharge	Shows the drain discharge interval (**) <sup>note 4</sup>	5 min	5÷40 min.	NO

\*= opening time (output active) fixed at 1 sec.

### 9.3.4 STOPPING THE COMPRESSOR

By pressing



For more than 3 seconds, the following flashing screen appears:



After 10 seconds, the compressor stops.

## 9.4 REMOTE CONTROL

For the remote control of the compressor, activate SWITCH 1 ON and connect your controller to Pin shown in the picture below:

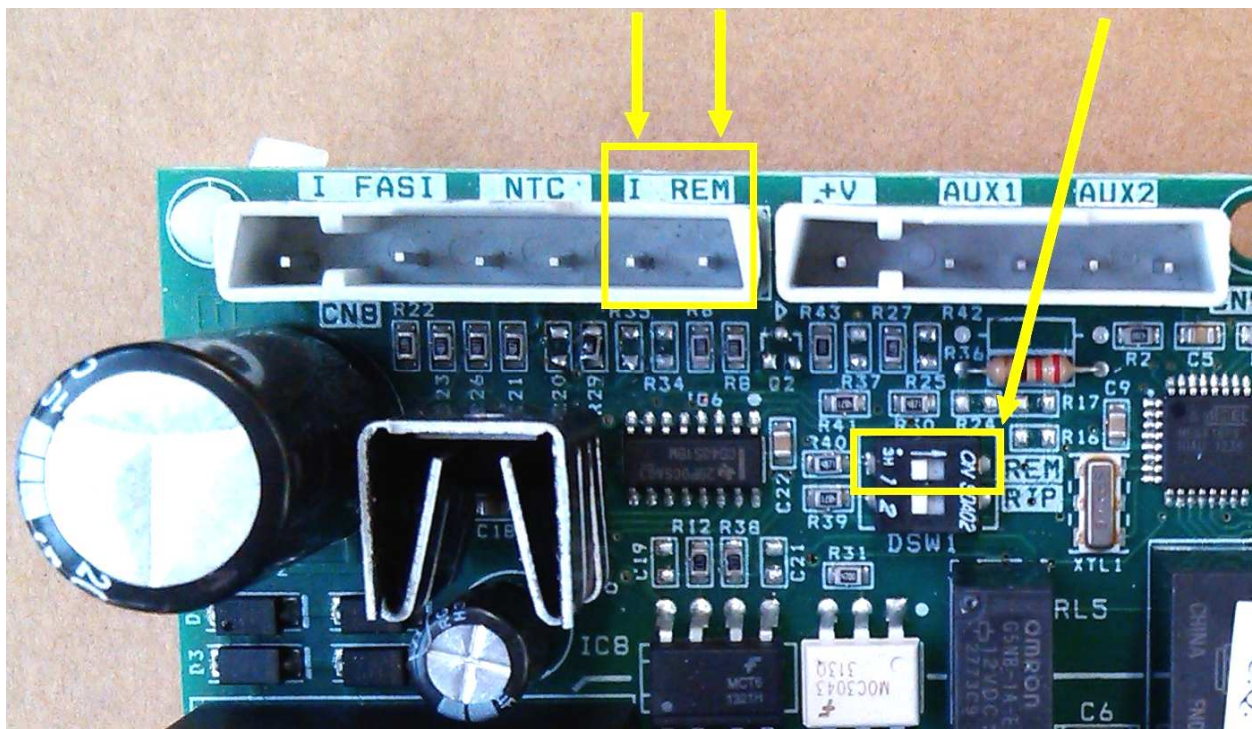

## 9.5 AUTOMATIC RESTART

To activate the AUTOMATIC RESTART of compressor, place the SWITCH 2 in the ON position as shown in the picture below:

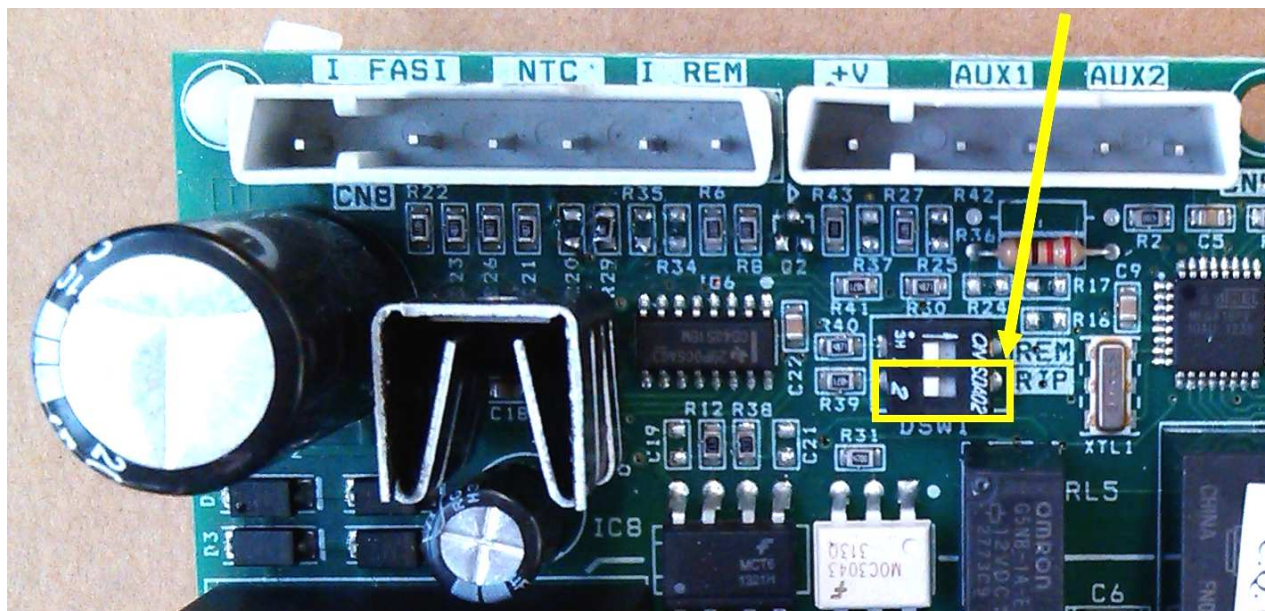

### ATTENTION

The rules stipulate the need for manual reset of the system in case of arrest for the absence of voltage. The above-mentioned change is at the discretion of the user, therefore ITALYCO Srl doesn't accept any responsibility for damage to persons and property with this type of use.

## 10 COMPRESSOR MAINTENANCE

### 10.1 SCHEDULED MAINTENANCE

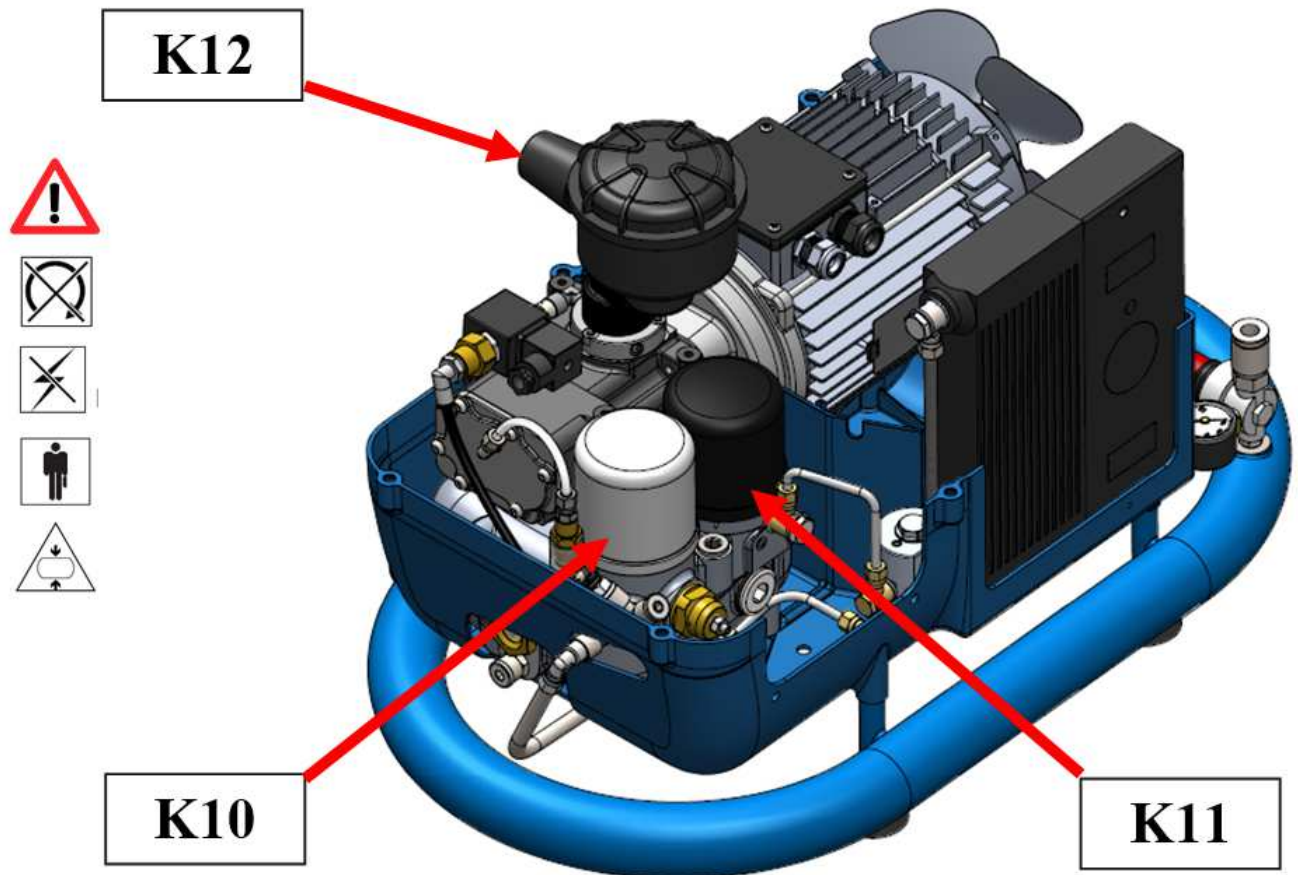

**CAUTION!!! USE ONLY ORIGINAL SPARE PARTS!!!**



**CAUTION!!! HOT PARTS INSIDE!!!**



**OIL LEVEL CHECKS AND TOP UPS MUST BE PERFORMED WITH THE MACHINE OFF AND WITH THE UNIT AT ATMOSPHERIC PRESSURE.**



**THE OIL REMOVED MUST BE DISCARDED IN COMPLIANCE WITH CURRENT LAW.**



**IN SEVERE WORKING ENVIRONMENTS (e.g.: PARTICULARLY DUSTY WORK SITES), THE MAINTENANCE INTERVAL MUST BE SHORTER.**



**INCORRECT MAINTENANCE OF THE OIL FILTER, AIR FILTER AND OIL SEPARATOR CAN DAMAGE THE UNIT.**

**LEAVING CARTRIDGES IN OPERATION FOR LONGER THAN THE INDICATED TIME CAN DAMAGE THE COMPRESSOR.**



**ALWAYS CAREFULLY COMPLY WITH THE SAFETY WARNINGS REGARDING USE OF THE MACHINE. THIS IS ABSOLUTELY ESSENTIAL.**



**MAINTENANCE MUST BE CARRIED OUT BY SPECIALISED PERSONNEL. ALWAYS FOLLOW CURRENT ACCIDENT PREVENTION STANDARDS (USE ADEQUATE PROTECTION).**

## 10.2 REPLACING OIL FILTER



Perform all maintenance as described in this manual or following the indications provided by the retailer or Authorized Service Centre. Open cover and remove the filter cartridge using the special spanner. Then replace the spent cartridge with a new one.



**Before screwing down the filter cartridge, oil the gasket.  
Manually screw down the new cartridge.**

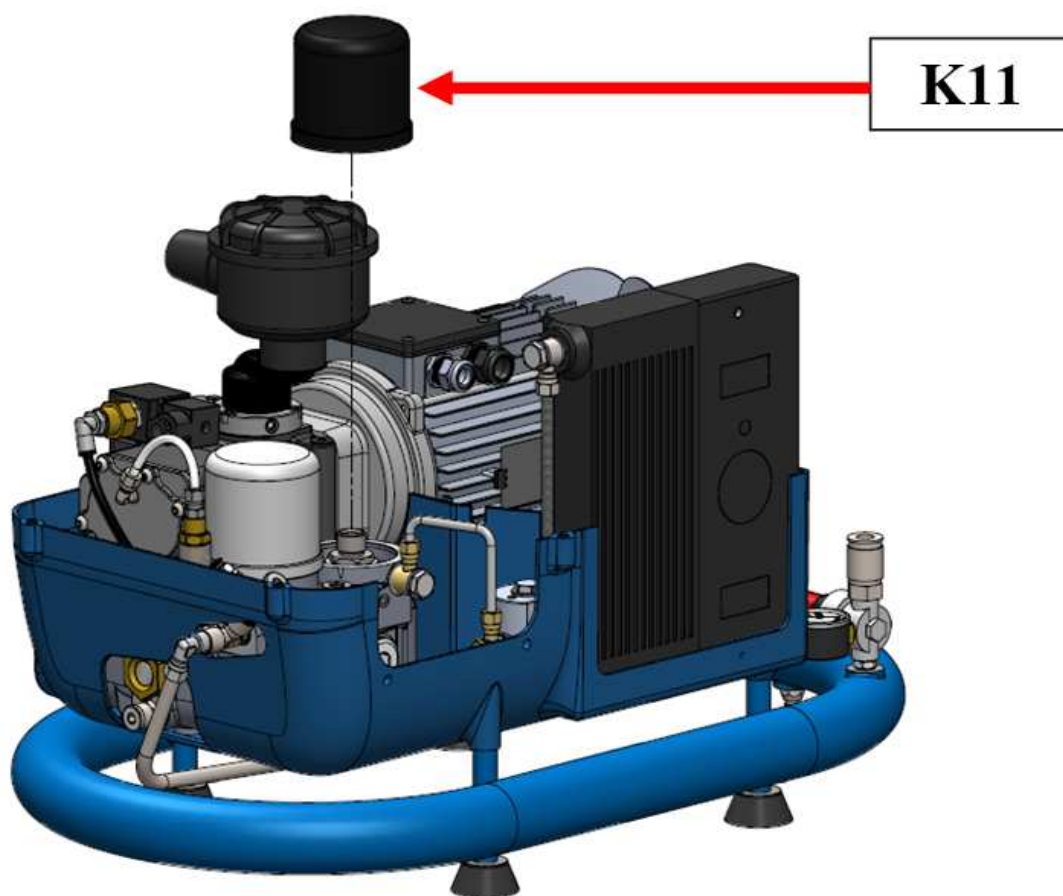



### 10.3 REPLACING OIL SEPARATOR FILTER



Replace the oil separator filter after the number of hours indicated in the manual or after checking its differential pressure. To do so, open the upper half-shell and remove the filter cartridge using the special spanner. Then replace the spent cartridge with a new one.

 **Before screwing down the oil separator cartridge, oil the gasket.  
Manually screw down the new cartridge.**

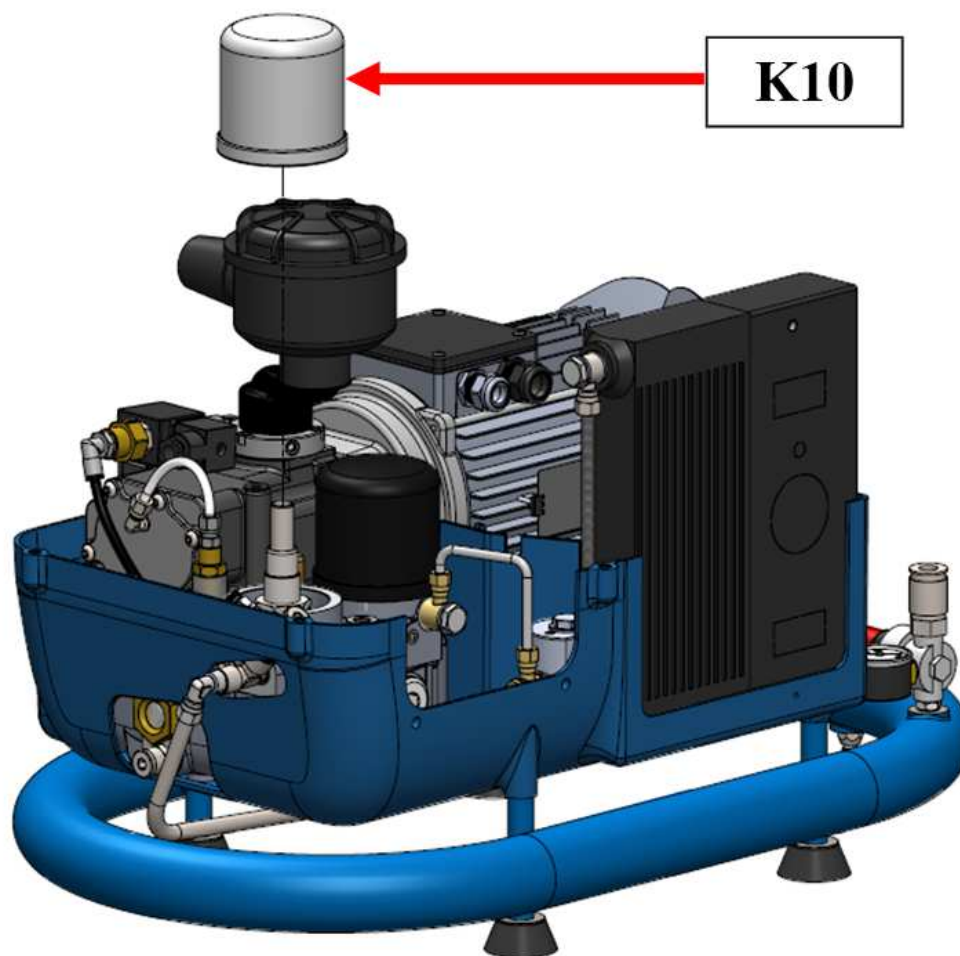

## 10.4 CHANGING THE OIL



Change the oil as indicated in the table on chap 10.6. Extending the number of hours before replacement depends on the type of oil used but in no case can oil be used for more than one year. If the compressor is not used frequently (a couple of hours a day), we recommend changing the oil every 6 months and periodically opening the oil drain ball valve to check for condensation residues.

 **When the oil drain ball valve is opened, oil starts flowing out of the screw assembly. Always keep on all necessary equipment to collect the oil.**

Open filling cap.  
Open emptying cap.

### ADAM 50

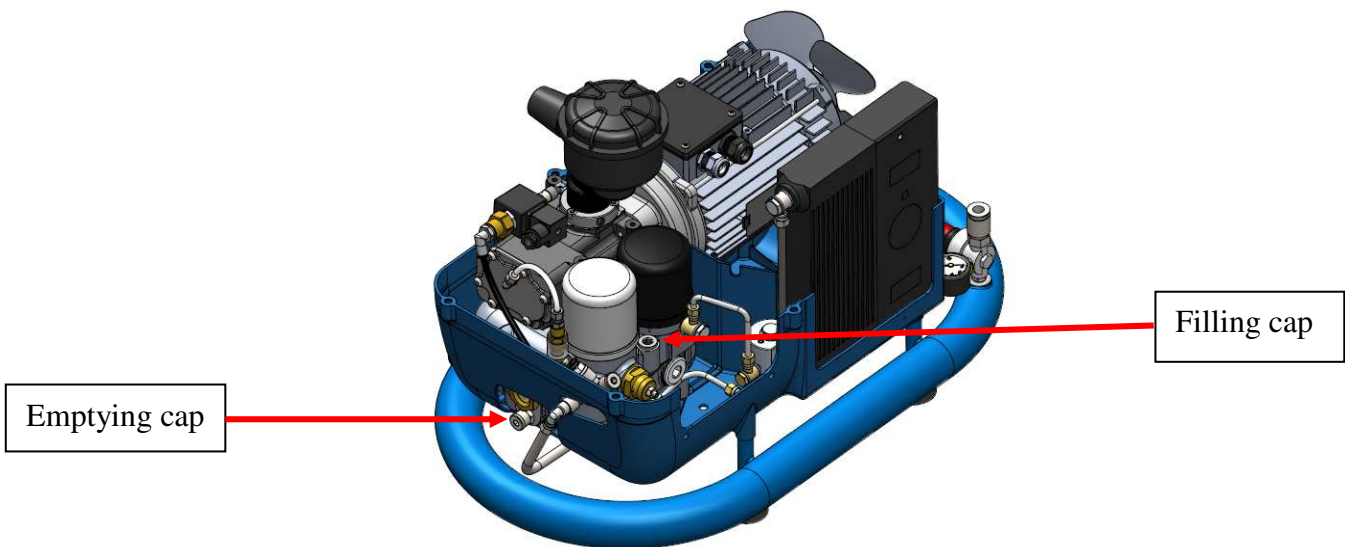

### ADAM 60

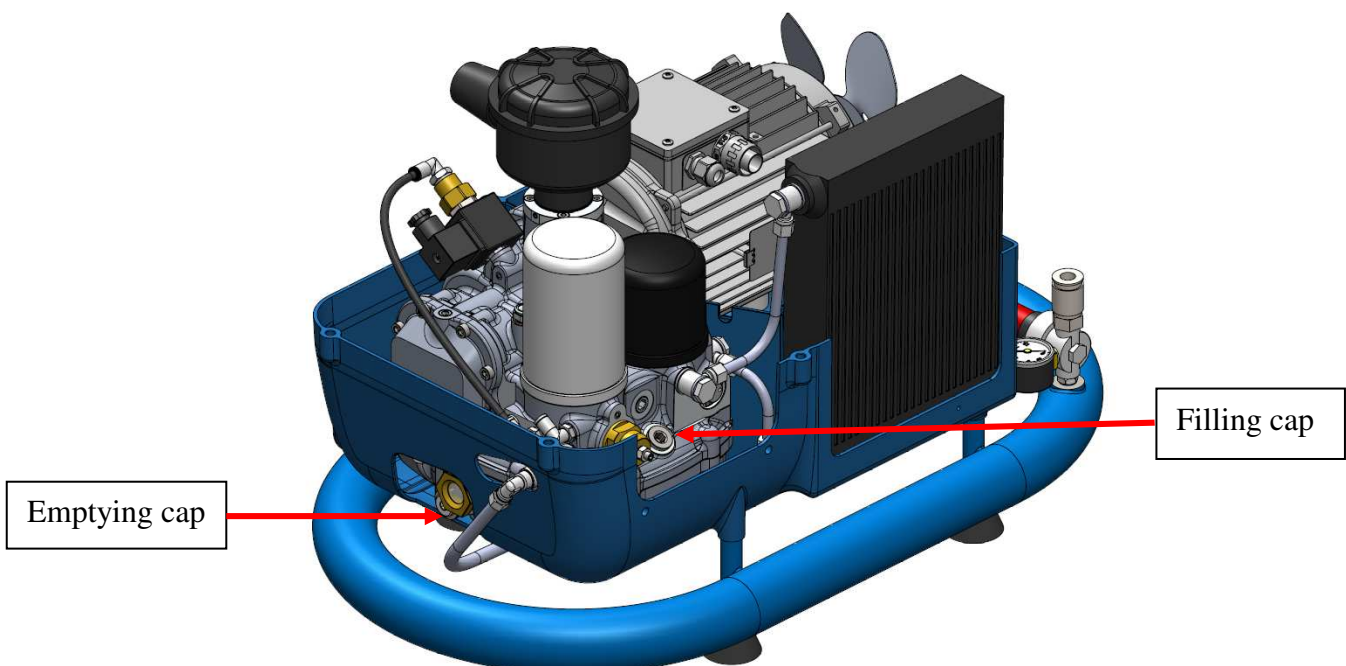

Once emptied, close the emptying cap.

Then top up the oil until the right level is read on the window (see figure 13). Then tighten the oil filling cap once more.

After having replaced the oil and oil filter, run the compressor for about 10 minutes, turn it off and check the oil level. If necessary, top up.



Figure 13



**Never mix different types of oil. Make certain that the oil circuit is completely empty before performing any maintenance. Always replace the filter at each oil change (chap. 10.6).**

## 10.5 REPLACING THE AIR FILTER



Replace the cartridge following the indications in the maintenance table.  
Take particular attention not to let any material fall into the suction valve.  
The duration of the air filter and proportionate to the type of environment and air contamination by dust. If the environment is heavily contaminated it is necessary to intensify the replacement of the air filter.

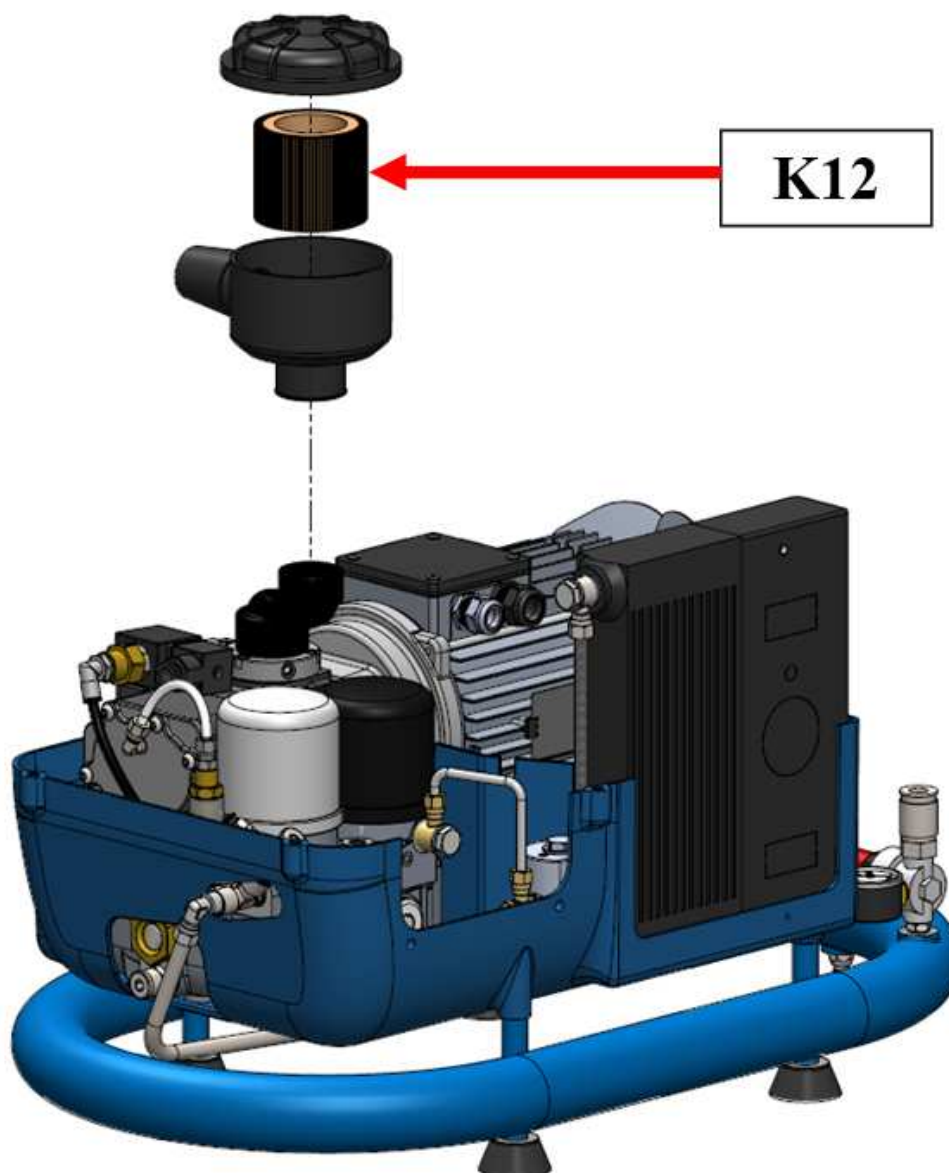

## 10.6 MAINTENANCE SCHEDULE



The following table shows a plan for maintenance of the compressor.

The working hours shown in the table refer to an optimal use of the machine and therefore may vary according to the work environment and the number of cycles.

The **Manufacturer** recommends keeping a log of the maintenance works performed on the compressor.

**MS: Maintenance staff**

**SP: Service and distribution partners ITALYCO**

Component Verification	Maintenance Control Type	HOURS	DESCRIPTION OF OPERATION	Operator control / maintenance
compressor Unit	Visual	Daily	General Inspection unit	MS

Component Verification	Maintenance Control Type	HOURS	DESCRIPTION OF OPERATION	Operator control / maintenance
Oil level	Control	Weekly	level Control	MS
Prefilter air intake	Control		General control and cleaning (if necessary)	
Oil radiators / air	Control		Cleaning (if necessary) of the radiators from various material / powder / oil residues, etc.	

Component Verification	Maintenance Control Type	HOURS	DESCRIPTION OF OPERATION	Operator control / maintenance
Oil filter	Replacement	500 / 6 months	Replacing the oil filter and oil recovery level	SP
Electric / remote control switch panel	Control and tightening		Terminals main electrical panel terminals and contactors star / delta	
Pipes, fittings, components	Control		Visual inspection leaks oil / air	
Belt drive	Control (where present)		belt tensioning control and eventual	
Oil cooler	Control		Control of the cooling system efficiency and / temperature	

<b>Component Verification</b>	<b>Maintenance Control Type</b>	<b>HOURS</b>	<b>DESCRIPTION OF OPERATION</b>	<b>Operator control / maintenance</b>
Air filter	Replacement	2000/ 1 year	filter replacement	SP
Oil filter	Replacement		Replacing the oil filter and oil recovery level	
Air separator filter / oil	Replacement		Changing the air / oil separator filter	
Replacing Oil (type Mineral)	Replacement		lubricating oil Substitution	
Belt drive	Control (where present)		belt tensioning control and eventual	

Component Verification	Maintenance Control Type	HOURS	DESCRIPTION OF OPERATION	Operator control / maintenance
Air filter	Replacement	4000 / 2 years	filter and pre-filter replacement	SP
Oil filter	Replacement		Replacing the oil filter and oil recovery level	
Air separator filter / oil	Replacement		Changing the air / oil separator filter	
Oil replacement (type Minerale <sup>2</sup> )	Replacement		lubricating oil Substitution	
Oil replacement (type Semi-synthetic / Sintetico <sup>2</sup> )	Replacement		lubricating oil Substitution	
main electric motor bearings	Control and greasing		Grease the motor bearings with grease specification	
Belt drive	Control (where present)		belt tensioning control and eventual	
Belt drive	Replacement (only for kpm 3,5)		Substitution of the belt and its tension	
Electric / remote control switch panel	Control and tightening		Terminals main electrical panel terminals and contactors star / delta	
<b>Suction regulator</b>	<b>Revision</b>		<b>Revision vacuum controller with dedicated spare parts kit</b>	
<b>Minimum air pressure regulator</b>	<b>Revision</b>		<b>Revision minimum air pressure controller with dedicated spare parts kit</b>	
<b>Thermostatic oil circuit regulator</b>	<b>Revision</b>	<b>Revision oil thermostatic controller with dedicated spare parts kit</b>		

<sup>1</sup> CAUTION

in case of excessive reduction in the oil level, you can generate overheating phenomena with possible formation of potentially flammable vapors

<sup>2</sup>Type OIL

The maintenance intervals / substitution with oil semi-synthetic / synthetic are doubled from 2,000 hours (with mineral oil) to 4,000 hours

## **10.7 UNSCHEDULED MAINTENANCE, COMMERCIAL PARTS, SPARE PARTS AND PERTINENT DOCUMENTATION**

Unscheduled maintenance must be performed by an Authorized Service Centre.

For any information, please log onto our website [www.italyco.net](http://www.italyco.net)

For any clarifications you may require, contact our **customer services department** or your area **retailer**.



## 11 TROUBLESHOOTING



Problem	Cause	Resolution
High oil temperature limit trips causing machine to stop.	Low oil level, High environmental temperature Oil cooler clogged Temperature probe failure	Top up oil level Check environmental temperature Clean oil cooler Replace temperature probe.
Motor thermal trip causes machine to stop. Main motor overloaded.	Low line voltage. High pressure of the oil separator.	Check the correct calibration of the thermal protection. Check that the electric power supply is correct. Check that power cables are firmly secured to the terminal. Check that the cables are not damaged. Check the main motor ventilation is free of any fouling or foreign objects. The oil separator differential pressure is above 1.0 bar causing high system absorption. Check the unit by qualified personnel.
Stopping the machine for intervention of the high pressure safety	The pressure exceeds the alarm set point. Transducer does not detect pressure properly.	Check the line pressure Check for proper operation of the transducer, if necessary replace it.
Stopping the machine because of the low temperature	Oil temperature lower than the value set on the electronic controller. Temperature probe faulty.	Check the environmental temperature and, if necessary, use a heating resistance on the oil circuit. Contact an authorized Service Centre.
Compressor runs but does not charge.	Suction valve does not open. Auxiliary power disconnected. Solenoid valve fuse blown. Breaking transmission elements between the motor and the screw.	Check that the transducer is connected both electrically and pneumatically.  Check that the solenoid valve installed on the suction regulator is functioning properly.  Check valve or minimum pressure valve failure. Contact an Authorized Service Centre.  Check the fuses for the solenoid valve installed on the terminal inside the starter itself.  Check and replace the elements of transmission failures.

<b>Problem</b>	<b>Cause</b>	<b>Resolution</b>
Oil leaking from air filter.	High oil level. Defective suction valve. The compressor during transport has been tilted excessively.	Drain the oil until the correct level is reached. For the valve, contact an Authorized Service Centre.
Opening of the safety valve	Working pressure too high Overpressure in the internal circuit. The oil separator cartridge is clogged. Safety valve is damaged	Restore correct working pressure from rating plate. Replace oil separator filter. Replace any defective safety valve.
Excessive oil consumption.	Oil not suitable for the compressor operation. Air-oil separator cartridge spent or defective. Oil recovery window clogged. Oil level too high.	Replace oil Fill machine with the oil indicated by the manufacturer. Replace oil separator cartridge. Clean or replace oil recovery window. Top up oil until it reaches the level indicated in the manual.

## 12 APPENDIX

### 12.1 MAINTENANCE CHECK SHEET

MAINTENANCE CHECK SHEET															
Operation hours	Prefilter panel		Air filter cartridge		Oil filter cartridge	Separator filter cartridge			Oil		Belt			Date	Sign
	Cleaning	Replacement	Cleaning	Replacement	Replacement	Pressure difference	Replacement	Check	Topping	Replacement	Check	Tension	Replacement		



## CAUTION!

- Never touch moving parts while the compressor is running.
- All compressor maintenance operations must be performed with the machine off (at environmental pressure and temperature) and with the unit unplugged.
- Maintenance must be carried out by qualified personnel. Always follow current accident prevention standards (use adequate protection).

The manufacturer reserves the right to make any modifications to the present manual it deems fit and to do so without prior notice.



The manufacturer is relieved of any responsibility for injuries and property damage caused by incorrect use of the compressor assembly, non-compliance or inadequate compliance with the safety criteria indicated herein, modifications (even minor modifications) and by tampering and use of non original spare parts.