

OPERATION AND MAINTENANCE MANUAL FOR KV 5,5-7,5-10-15-20 COMPRESSORS

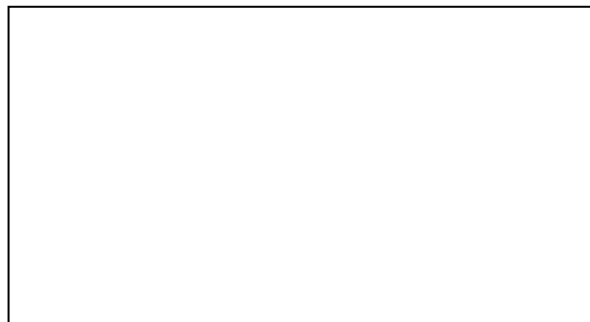

ENGLISH VERSION

ITALYCO SRL
- Via Vizzano, 44 - 40037 –
Pontecchio Marconi (BO)

BACKGROUND

Never use the compressor in an inappropriate way, but only as recommended by the **Manufacturer**. The **Manufacturer** reserves the right to update the technical data contained in this manual without prior notice. Before using the compressor, carefully read the instructions in the following manual.

IMPORTANCE OF THE MANUAL

This **INSTRUCTION MANUAL** is your guide to **INSTALLATION, USE, MAINTENANCE** of the compressor you purchased. We advise you to strictly follow all the recommendations contained in it, as the good functioning and duration of the compressor depend on the correct use and methodical application of the maintenance instructions given below. It should be remembered that, should difficulties or inconveniences arise, the **AUTHORIZED ASSISTANCE CENTERS** are at your complete disposal for any clarification or possible intervention. The **Manufacturer** therefore declines any responsibility for incorrect use or inadequate maintenance of the compressor. The **INSTRUCTION MANUAL** is an integral part of the compressor. Keep this manual for the duration of the compressor.

Ensure that any updates received by the **Manufacturer** are incorporated into the manual. Transfer the manual to any other user or subsequent owner of the compressor.







Preservation of the manual:

- Use the manual in such a way as not to damage all or part of the contents.
- Do not remove, tear or rewrite parts of the manual for any reason.
- Keep the manual in an environment protected from humidity and heat.

SYMBOLS USED

The following **SYMBOLS** are used throughout the course of this publication to draw the attention of the operator to the behavior to be adopted in every operating situation

These symbols can be placed next to a text, next to a figure or at the top of the page. Pay the utmost attention to the meaning of the symbols: their function is that of not having to repeat the technical concepts or safety warnings, therefore to be considered "**reminders**". Consult the table below whenever there are any doubts about their meaning.

	READ THE INSTRUCTION BOOKLET Before positioning, operating or working on the compressor, read the user and maintenance manual carefully.
	ATTENTION highlights an important description regarding dangerous conditions, safety warnings, information of the utmost importance.
	STOPPING MACHINE every operation must be carried out with the machine stopped.
	CAUTION MACHINE IN PRESSURE each operation must be performed with the machine without pressure inside the oil separator tank (0 bar).
	REMOVE TENSION every operation on the machine must be carried out with the power supply switched off.
	QUALIFIED PERSONNEL any intervention highlighted by this symbol is the exclusive responsibility of a specialized technician.

SUMMARY

1	GENERAL WARNINGS AND INFORMATION FOR THE USER	7
1.1	DEFINITION OF REGULATED RELATIONSHIPS	7
1.1.1	DECLARATIONS	7
1.1.2	WARRANTY.....	8
1.1.3	RETURNS	8
2	CE MARKING.....	9
2.1	CAUTIONS AND SAFETY WARNINGS	10
2.1.1	INSTRUCTIONS FOR SAFE OPERATION	10
2.2	CONTACTS AND USEFUL ADDRESSES	13
3	DESCRIPTION OF THE MACHINE AND OPERATING PRINCIPLE.....	14
3.1	MACHINE DESCRIPTION	14
3.2	OPERATING PRINCIPLE.....	15
4	DATA AND TECHNICAL SPECIFICATIONS.....	16
5	DIMENSIONS.....	18
6	INSTALLATION	30
6.1	CHARACTERISTICS AND STORAGE CONDITIONS.....	30
6.2	TRANSPORT	30
6.3	UNPACKING	30
6.4	HANDLING.....	31
6.5	LOCATION	32
6.6	FOUNDATIONS	32
6.7	CONNECTION AND START-UP	34
6.7.1	GENERAL WARNINGS.....	34
6.7.2	CONNECTING THE POWER SUPPLY CORD OF THE COMPRESSOR	35
6.7.3	CONNECTING THE COMPRESSOR TO THE ELECTRICAL POWER SUPPLY	36
6.7.4	INFORMATION ON THERMAL RELAY CALIBRATION	38
6.7.5	WIRING DIAGRAM.....	39
6.7.6	COMPRESSOR CONNECTION TO ELECTRICAL POWER SUPPLY	39
6.7.7	FIRST START-UP.....	40
6.8	CLEANING AND DISINFECTION	41

6.9	REINSTALLATION AND REUSE	41
6.10	DEMOLITION AND DISPOSAL	41
7	OPERATION AND USE	42
7.1	DESCRIPTION OF THE OPERATION	42
7.2	RANGE OF APPLICATIONS	42
7.3	PROPER AND IMPROPER USE	42
7.4	OPERATING AND ENVIRONMENTAL LIMITS	42
7.5	WORKSTATION AND DANGEROUS AREAS	42
7.6	SAFETY DEVICES AND SIGNALS	43
7.6.1	POSITION OF THE LABELS	44
7.7	PERSONAL PROTECTIVE EQUIPMENT, SAFE WORKING PROCEDURES AND TRAINING	45
7.8	COMPRESSOR LUBRICATION	45
7.8.1	GENERAL RECOMMENDATIONS	45
7.8.2	USING THE COMPRESSOR WITH SYNTHETIC OILS	46
8	INSTRUCTIONS FOR THE USER	47
8.1	BUTTON LAYOUT	48
8.2	DESCRIPTION OF THE OPERATIONS TO BE PERFORMED	48
8.3	PROGRAMMING KEYPAD	49
8.4	ALARMS LIST	50
8.5	START, STOP AND EMERGENCY STOP FUNCTIONS	51
8.6	RESET CONDITIONS	51
9	COMPRESSOR MAINTENANCE	52
9.1	SCHEDULED MAINTENANCE	52
9.1.1	BELT TENSIONING	53
9.1.2	USING AN OPTIKRIK TENSION AUGER	57
9.1.3	SUCTION PRE-FILTER MAINTENANCE	58
9.1.4	REPLACING THE OIL FILTER	60
9.1.5	REPLACING THE OIL SEPARATOR FILTER	60
9.1.6	CHANGING THE OIL	61
9.1.7	REPLACING THE AIR FILTER	61
9.1.8	MAINTENANCE SCHEDULE	62
9.2	UNSCHEDULED MAINTENANCE	71

10	TROUBLESHOOTING	72
11	COMMERCIAL PARTS, SPARE PARTS AND PERTINENT DOCUMENTATION	74
12	APPENDIX	75
12.1	MAINTENANCE CHECK SHEET	75

1 GENERAL WARNINGS AND INFORMATION FOR THE USER

1.1 DEFINITION OF REGULATED RELATIONSHIPS

1.1.1 DECLARATIONS

The compressor must be used solely as indicated in this manual. This manual must be kept on hand in a known, easily accessible place because it should be used throughout the machine's entire working life.

When making any requests, always indicate model and serial number.

DECLARATION OF CONFORMITY

ITALYCO Srl, the manufacturer, on its own responsibility, declares that the air compressor identified by the label on the front page of this document, complies with the essential requirements laid out in the following DIRECTIVES – STANDARDS written in the certificate of conformity attached to the machine.

ITALYCO Srl holds the relevant technical dossier.

1.1.2 WARRANTY

ITALYCO Srl guarantees its products from manufacturing or design defects for a period of 24 months from the date of initial start-up. To inform ITALYCO Srl of this date, fill out the special form supplied with the machine technical documentation and send it in.

If no communication is received, the warranty shall be recognized for 12 months starting from the date on which the unit was shipped; that is the date indicated on the ITALYCO Srl invoice.

The warranty does not cover parts subject to wear.

Repair works covered under the warranty can only be performed by ITALYCO Srl or ITALYCO Srl authorized Service Centre.

Shipment of any product being returned for service under the warranty must be authorized in advance, and in writing, by ITALYCO Srl. Moreover, ITALYCO Srl., in its unquestionable wisdom, can decide whether to authorize such shipment or have one of its Authorized Service Centres do the work.

In both cases, shipment to ITALYCO Srl. must be made carriage paid with shipping costs charged in the invoice. Repairs or replacements covered by the warranty include free replacement of parts of the machine that are recognized as defective.

The warranty does not cover damages caused by negligence, by incorrect use or installation or by non compliance with the warnings indicated in the “Operation and Maintenance Manual”. Moreover the warranty is voided if modifications or repairs are made with non original ITALYCO Srl spare parts or performed by anyone not authorized to do so by ITALYCO Srl

Defective parts replaced under the warranty are retained by the Authorized Service Centre. The warranty does not cover repairs or reimbursement for damage due to shipping (to or from the Authorized Service Centre). The warranty does not cover any type of reimbursement for injuries or damages to people or things derived from improper use of the model purchased or due to machine down time (the customer must take steps to prevent this). Service covered under the warranty is guaranteed only to purchasers who have met their contractual and administrative obligations and who are able to show the documentation certifying the purchase period. This is the only valid warranty recognized by ITALYCO Srl COURT HAVING JURISDICTION.

For any disputes the competent court is that of Bologna, Italy.

1.1.3 RETURNS

Returns are made using the RMA (return material authorization) procedure.

To open said procedure, the customer must send a request to ITALYCO Srl.

2 CE MARKING

The CE marking certifies that the compressor complies with the health and safety requirements outlined in the European Directives indicated in the EC declaration of conformity.

The marking is printed with silver lettering on a black polyester adhesive label (L:90mm H:80mm). The label is placed as indicated in figure 1 and bears the following information:

- **CE marking**
- **Compressor model**
- **Serial number**
- **Maximum working pressure**
- **Power supply voltage and frequency**
- **Nominal power**
- **Weight**
- **Manufacture year**



	
MODEL	
PART N°	
SERIAL N°	
MAX WORKING PRESS.	
VOLTAGE/FREQUENCY	
POWER SUPPLY	
WEIGHT	
MANUFACTURE YEAR	

Figure 1

2.1 CAUTIONS AND SAFETY WARNINGS



Read this operation manual carefully before performing any operations. Non-compliance with the instructions contained herein can lead to injury and property damage.

- The machine has been designed and built to operate as reported below. Any other use is considered unacceptable.
- Only qualified personnel can install and service the machine. Always follow accident prevention standards.
- The manufacturer is relieved of any responsibility for injuries and machine or property damage caused by incorrect use of the compressor, non-compliance or inadequate compliance with the safety criteria reported herein, modifications (even minor modifications) and by use of non original spare parts.

2.1.1 INSTRUCTIONS FOR SAFE OPERATION



CAUTION!

Below is a list of important instructions for safe use of the compressor. Follow these instructions carefully. Improper use or maintenance of the compressor can cause user injury.

1. Never Touch any Moving Parts

Never allow parts of the body to come near moving parts of the machine.

2. Never Use the Compressor if the Protection Guards have been Removed

Never use the compressor unless all guards are assembled. If maintenance requires removing any of the guards, make sure that they are properly reinstalled before starting up the unit. Never bypass the safety devices installed on the compressor. This is strictly forbidden.

3. Protective Grids

Never insert objects or body parts into protective grids as this can cause injury and can damage the compressor.

4. Use the Compressor Correctly

Always operate the compressor following the instructions given in this manual. Never allow children or unauthorized persons to use the machine.

5. Always Wear Eye Protection

Always wear goggles or other equivalent form of eye protection. Do not direct air toward parts of the body, your own or others.

6. Work Clothing

Do not wear inappropriate clothing or accessories. If necessary, wear a cap that covers the hair.

7. Use the Compressor Sensibly

Never use the compressor while under the effect of alcohol, drugs or medications that can cause drowsiness.

8. Personnel Intervention

Before performing any form of intervention, the personnel must be aware of all compressor functions and controls.

9. Compressor Usage

Never use the compressor for any purpose other than those specified in the user's manual.

10. Air Jets

Never direct air jet toward persons or animals.

11. Hot Parts

To prevent burns, never touch the hoses, motor or other hot parts.

12. Work Area

Keep the compressor work area clean and well ventilated. Never use the compressor in a place containing paints, solvents or combustible/explosive materials.

13. Compressor Maintenance

Check the outside of the compressor. If the power supply cord is damaged, repair or replace it. If necessary, contact an Authorized Service Centre.

14. Check for Defective Parts and Air Leaks

Check alignment of moving parts, hoses, pressure gauges, pressure reducers, pneumatic connections or other parts important to compressor function. Make certain that all screws, bolts and lids are thoroughly secured. Any damaged parts must be repaired by an Authorized Service Centre.

15. Protect yourself against Thermal Shocks

Prevent accidentally coming into contact with metal parts of the compressor such as hoses, tanks or grounded parts. Never use the compressor if water or moisture is present in the area.

16. Disconnect the Compressor

When servicing the compressor or when it is not running, always disconnect it from the power supply and completely vent the pressure in the tank.

17. Handling

Never move the compressor while it is connected to the power supply or when the tank is pressurized. Before unplugging the compressor make certain that the switch is set to OFF.

18. Precautions for the Power Supply Cord

Never unplug the unit by pulling on the cord. Never step on or crush the power supply cord. Keep it away from heat, oil or sharp surfaces. Never turn off the compressor by pulling on the power supply cord. Use the red emergency button to stop the compressor.

19. Electrical Extension Cords

If the compressor is used outdoor, use power supply cords rated for outdoor use.

20. Cleaning of the Intake Grid and Plastic Parts

Keep the ventilation grid clean. If the unit is used in a particularly dirty environment, clean the grid regularly. Never use solvents, thinners or other substances containing hydrocarbons as they can damage the plastic parts. Clean with soapy water or an appropriate liquid cleaner.

21. Compressor Rated Voltage

Use the compressor at the voltage indicated on the label. Using the compressor at a different voltage can burn out or damage the electric motor.

22. Compressor Defects

If the compressor makes strange noises or vibrates excessively during operations, check that it is functioning properly and, if necessary, contact an Authorized Service Centre.

23. Spare Parts

Use only original spare parts which can be purchased from our distributors. Use of non original spare parts voids the warranty and can lead to compressor malfunction. Repairs must be carried out by an Authorized Service Centre.

24. Pneumatic Circuit

Use hoses, connections and pneumatic tools rated to handle pressures above the operating pressure.

25. Tank

Never unscrew any tank connections without first checking to ensure that the pressure has been vented. Never make holes, welds or modifications on the tank.

26. Compressor Modifications

Never make any unauthorized modifications to the compressor. Such modifications can cause damage and serious injury. Consult an Authorized Service Centre for any operations.

27. Using the Compressor for Painting

Never use the compressor in confined spaces or near open flames. Make certain that the work area is adequately ventilated. In addition, wear a special mask to protect nose and mouth.

28. Keep the Compressor Horizontal

To ensure correct functioning of the compressor, it is advisable to work in a near-to horizontal position.



KEEP THIS MANUAL INTACT AND ON HAND, AVAILABLE TO ANYONE USING THE COMPRESSOR!



WE RESERVE THE RIGHT TO MAKE ANY MODIFICATIONS WE DEEM NECESSARY WITHOUT PRIOR NOTICE!

2.2 CONTACTS AND USEFUL ADDRESSES

Our technical services department is at your disposal, ready to provide any information you may need and to help you resolve any problems that may arise.

For any information, please log onto our website www.italyco.net

For any clarifications you may require, contact our **customer services department** or your area **retailer**.

Only original spare parts can guarantee best performance of our compressors.

We recommend carefully following the instructions given in the chapter on **maintenance** and **always use only original spare parts**.

Using not original parts automatically voids the warranty.

3 DESCRIPTION OF THE MACHINE AND OPERATING PRINCIPLE

3.1 MACHINE DESCRIPTION

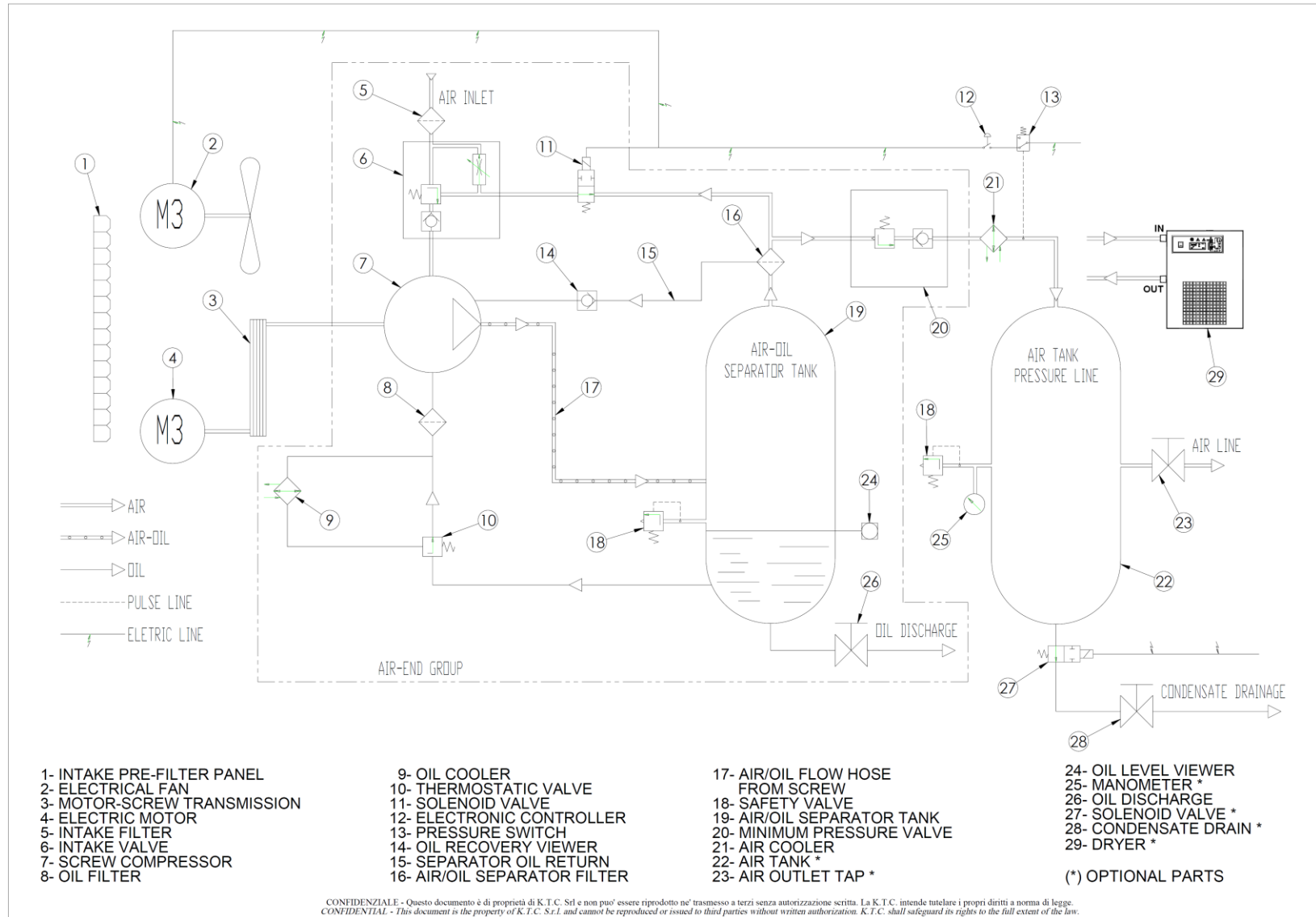

3.2 OPERATING PRINCIPLE

- During the initial phase of start up, the electric motor ref. 4 (with "star" power supply), rotates slowly. The solenoid valve ref. 11 is not powered and thus the intake valve ref. 6 it controls remains closed. The length of this phase can be set.
- During the second phase, the "delta" power supply accelerates the motor to reach the set operating r.p.m. The solenoid valve ref. 11 is powered and the intake valve ref. 6 is opened, thus allowing air to pass through the intake filter ref. 5 and enter the screw compressor ref. 7. This starts the compression phase.
- The air/oil mixture delivered by the screw compressor ref. 7 is conveyed into the air/oil separator tank ref. 19.
- An initial portion of the oil is separated from the air mechanically and deposits at the bottom of the tank while the air collects at the top.
- By force of pressure the air is forced to flow through the oil separator filter ref. 16 and, after further separation of the oil, it is sent on to the low pressure valve ref. 20. This allows passage of the air only after the pressure set point has been reached. When this happens, the air passes through the air radiator ref. 21, where it is cooled, and then continues on to the operating tank ref. 22.
The oil removed from the air inside the oil separator filter is sent, through the oil return from separator line ref. 15, into the screw compressor. The amount of oil can be monitored through oil recovery window ref. 14.
- In the model with drier ref. 29, the air passes through the drier before reaching the operating tank.
- Unless the unit has an automatic drainage, the condensate accumulated inside the tank must be eliminated manually through the condensate drainage ref. 28.
- The pressure sends oil at the bottom of the tank to the thermostatic valve ref. 10. This valve sends the oil with a temperature above the set point to the oil radiator ref. 9 where it is cooled. Once cooled, the oil returns to the thermostatic valve, is mixed with hot oil coming from the tank and is again checked by the thermostatic valve. Once the temperature set point (low) is exceeded, the oil is sent to the oil filter ref. 8 and then into the screw compressor.
- When the set maximum working pressure is reached, the pressure switch ref. 13 remove power from the solenoid valve ref. 11 and trips the circuit. The intake valve ref. 6 closes air flow and the compressor enters in "no-load" operating mode. This situation remains in force until the system minimum pressure setting is reached.
If consumption is low or has stopped unit will continue operate in no-load mode for a set amount of time and then reverts to stand-by mode.

4 DATA AND TECHNICAL SPECIFICATIONS

Model	KV 5,5	KV 7,5	KV 10
Machine type	Oil Injected Screw Compressor		
Drive	Belt Driven		
Screw type	Pack Smart V60		
Type of fluid handled	Air		
Flow rate (ISO 1217:2009 annex C)**	0,49 m ³ /min – 17,3 cfm	0,69 m ³ /min – 24,4 cfm	0,98 m ³ /min – 34,6 cfm
Max. working pressure	13 bar g - 188.5 psi g	13 bar g - 188.5 psi g	13 bar g - 188.5 psi g
Min. working pressure	5 bar g - 72.5 psi g	5 bar g - 72.5 psi g	5 bar g - 72.5 psi g
Maximum power consumption**	4 kW - 5 hp	5.5 kW - 7hp	7.5 kW - 10hp
Max. air/oil outlet temperature	105 °C - 221°F	105 °C - 221°F	105 °C - 221°F
Max. environmental temperature	45 °C - 113 °F	45 °C - 113 °F	45 °C - 113 °F
Min. environmental temperature*	5 °C - 41 °F	5 °C - 41 °F	5 °C - 41 °F
Weight	140 kg – 308,6 lb 170,5 kg – 375,9 lb + D 220,5 kg – 486,1 lb 270lt 231,5 kg – 510,4 lb 270lt (13 bar) 251 kg – 553,4 lb 270lt + D 262 kg – 577,6 lb 270lt + D (13 bar)	148 kg – 326,3 lb 178,5 kg – 393,5 lb + D 228,5 kg – 503,8 lb 270 lt 239,5 kg – 528 lb 270lt (13 bar) 259 kg – 571 lb 270lt + D 270 kg – 595,2 lb 270lt + D (13 bar) 271,5 kg – 598,6 lb 500 lt 304,5 kg – 671,3 lb 500 lt (13 bar) 302 kg – 665,8 lb 500 lt + D 335 kg – 738,5 lb 500 lt + D (13 bar)	148 kg – 326,3 lb 179,5 kg – 395,7 lb + D 228,5 kg – 503,8 lb 270 lt 239,5 kg – 528 lb 270lt (13 bar) 260 kg – 573,2 lb 270lt + D 271 kg – 597,5 lb 270lt + D (13 bar) 271,5 kg – 598,6 lb 500 lt 304,5 kg – 671,3 lb 500 lt (13 bar) 303 kg – 668 lb 500 lt + D 336 kg – 740,8 lb 500 lt + D (13 bar)
Power supply voltage	See Machine Label		
Oil charge	3,7 lt.	3,7 lt.	3,7 lt.
Air outlet connection	1/2”	1/2”	1/2”
Maximum fan flow rate	3135 m ³ /h	3135 m ³ /h	3135 m ³ /h
Oil residue in air	<3 ppm	<3 ppm	<3 ppm
Noise level***	65	66	67
Tank	270 lt	270/500 lt	270/500 lt

* When the environmental temperature is below 5°C, an ISO VG 32 lubricant must be used

** Value detected with working pressure: **10 bar g**

*** Noise measured in an open field at 1 metre from the unit ±3 dB(A) at maximum working pressure.

Model	KV 15	KV 20
Machine type	Oil Injected Screw Compressor	
Drive	Belt Driven	
Screw type	Pack Smart V75	
Type of fluid handled	Air	
Flow rate (ISO 1217:2009 annex C)**	1,46 m ³ /min – 51,6 cfm	1,99 m ³ /min – 70,3 cfm
Max. working pressure	13 bar g - 188.5 psi g	13 bar g - 188.5 psi g
Min. working pressure	5 bar g - 72.5 psi g	5 bar g - 72.5 psi g
Maximum power consumption**	11 kW - 15 hp	15 kW – 20 hp
Max. air/oil outlet temperature	105 °C - 221°F	105 °C - 221°F
Max. environmental temperature	45 °C - 113 °F	45 °C - 113 °F
Min. environmental temperature*	5 °C - 41 °F	5 °C - 41 °F
Weight	224 kg – 493,8 lb 257,5 kg – 567,7 lb + D 304,5 kg – 671,3 lb 270 lt 315,5 kg – 695,6 lb 270lt (13 bar) 338 kg – 745,2 lb 270lt + D 349 kg – 769,4 lb 270lt + D (13 bar) 347,5 kg – 766,1 lb 500 lt 380,5 kg – 838,9 lb 500 lt (13 bar) 381 kg – 840 lb 500 lt + D 414 kg – 912,7 lb 500 lt + D (13 bar)	234 kg – 515,9 lb 269,5 kg – 594,1 lb + D 314,5 kg – 693,4 lb 270 lt 325,5 kg – 717,6 lb 270lt (13 bar) 350 kg – 771,6 lb 270lt + D 361 kg – 795,9 lb 270lt + D (13 bar) 357,5 kg – 788,2 lb 500 lt 390,5 kg – 860,9 lb 500 lt (13 bar) 393 kg – 866,4 lb 500 lt + D 426 kg – 939,2 lb 500 lt + D (13 bar)
Power supply voltage	See Machine Label	
Oil charge	7,2 lt.	7,2 lt.
Air outlet connection	3/4”	3/4”
Maximum fan flow rate	3135 m ³ /h	3135 m ³ /h
Oil residue in air	<3 ppm	<3 ppm
Noise level***	68	68
Tank	270/500 lt	270/500 lt

* When the environmental temperature is below 5°C, an ISO VG 32 lubricant must be used

** Value detected with working pressure: **10 bar g**

*** Noise measured in an open field at 1 metre from the unit ±3 dB(A) at maximum working pressure.

5 DIMENSIONS

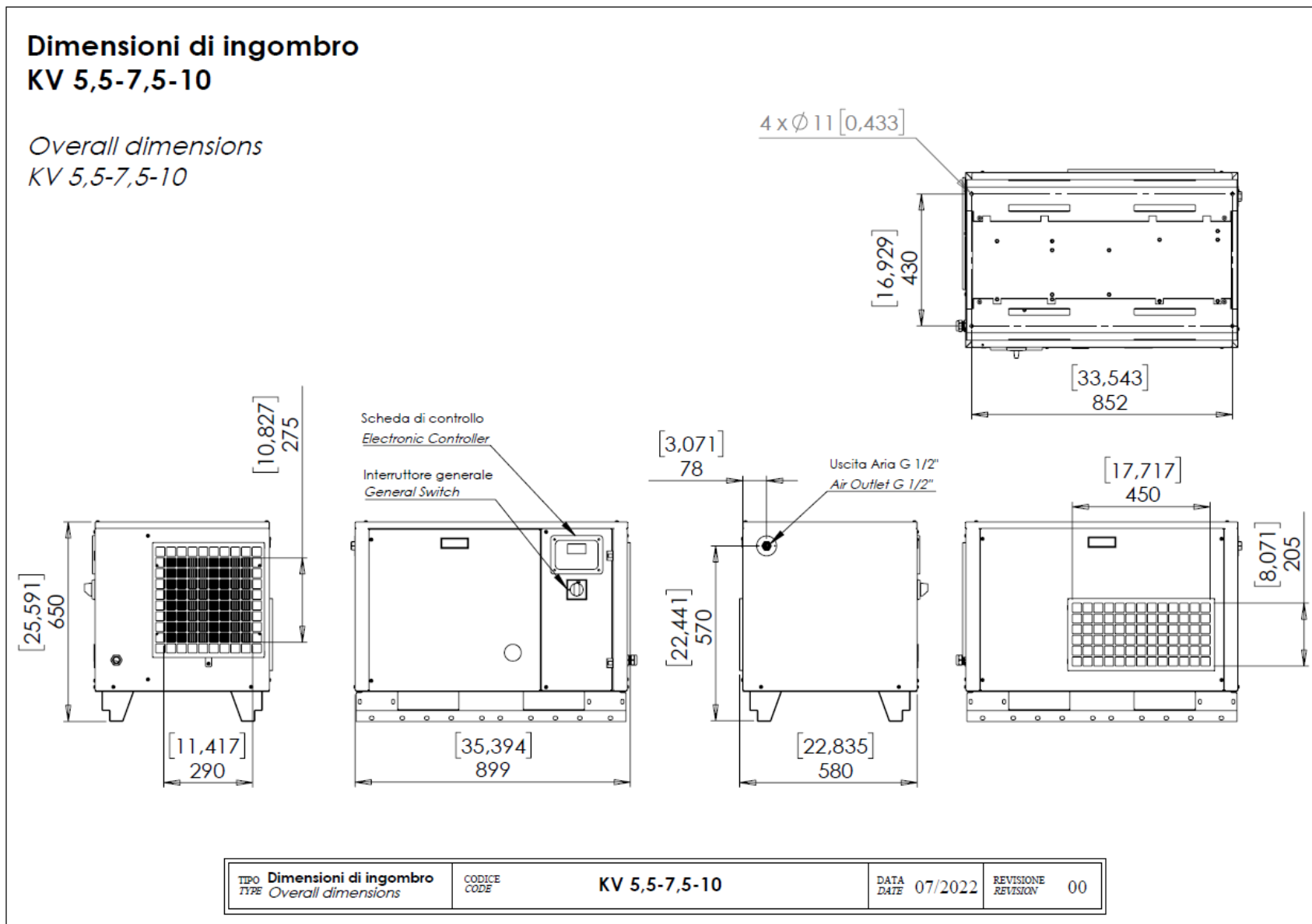

Dimensioni di ingombro KV 5,5-7,5-10 con essiccatore

Overall dimensions
KV 5,5-7,5-10 with dryer

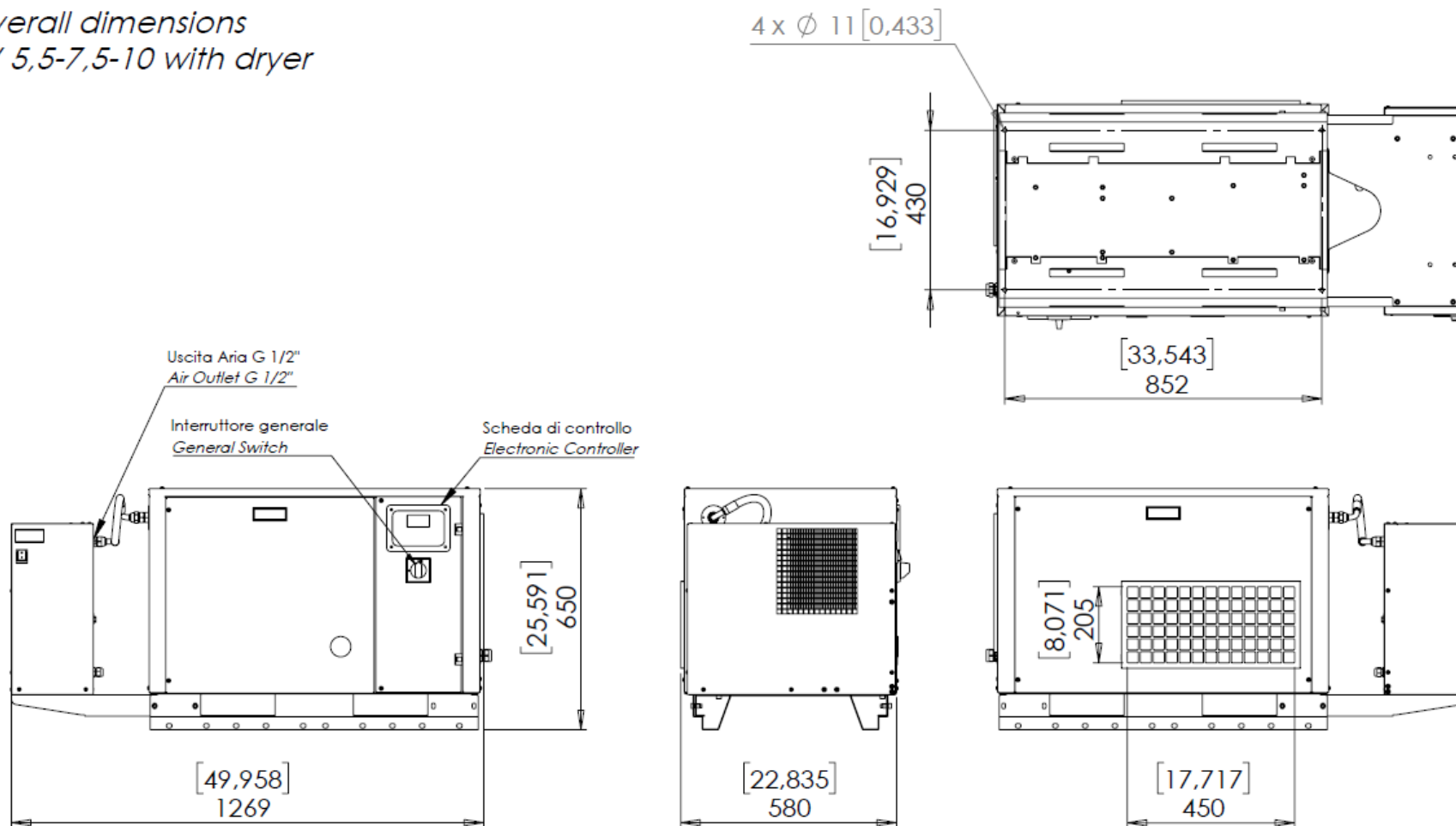

TIPO TYPE	Dimensioni di ingombro Overall dimensions	CODICE CODE	KV 5,5-7,5-10	DATA DATE	07/2022	REVISIONE REVISION	00
--------------	---	----------------	----------------------	--------------	---------	-----------------------	----

Dimensioni di ingombro KV 5,5-7,5-10 270LT

Overall dimensions
KV 5,5-7,5-10 270LT

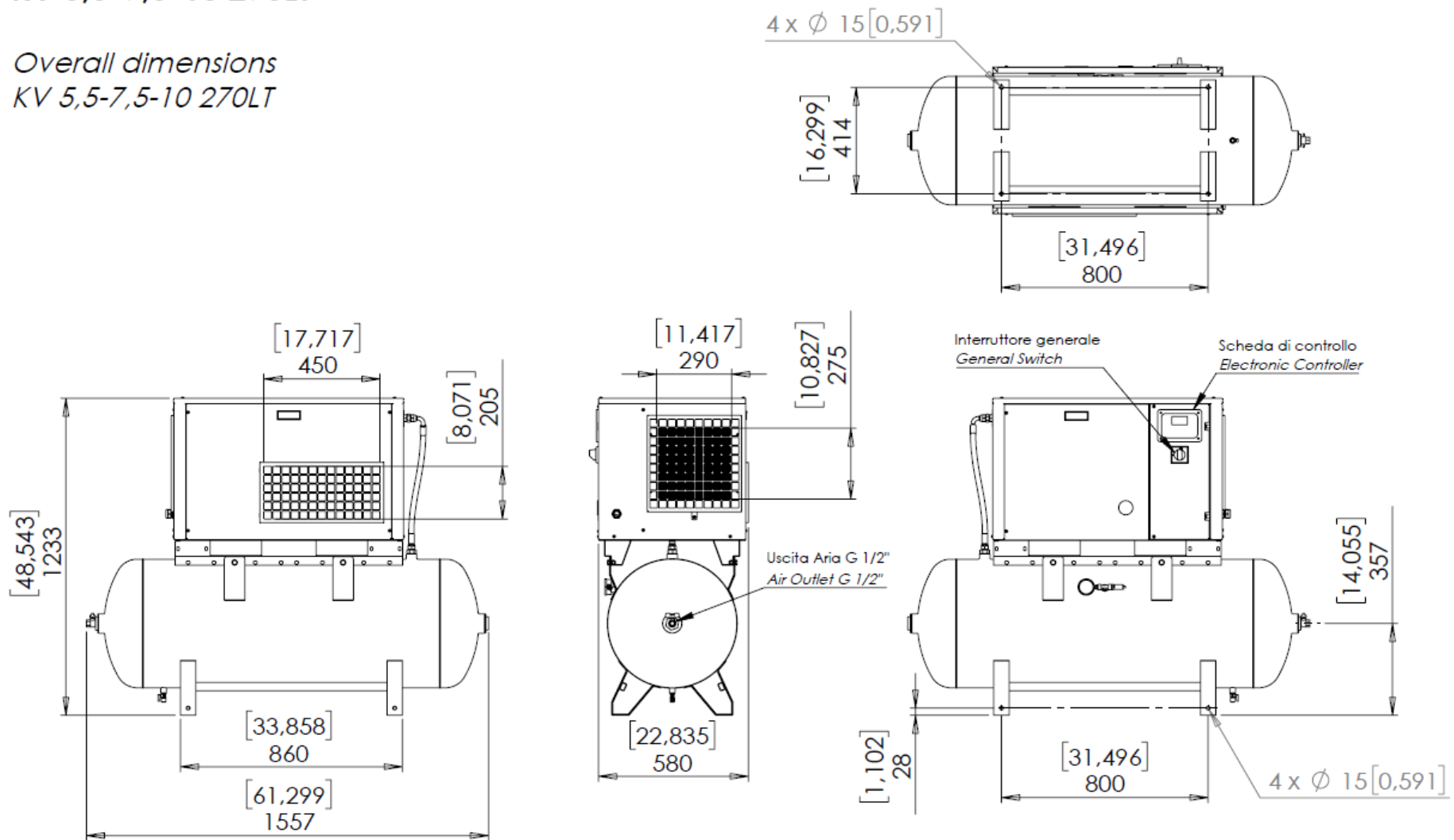

TIPO TYPE	Dimensioni di ingombro Overall dimensions	CODICE CODE	KV 5,5-7,5-10	DATA DATE	07/2022	REVISIONE REVISION	00
--------------	--	----------------	---------------	--------------	---------	-----------------------	----

Dimensioni di ingombro KV 5,5-7,5-10 270LT con essiccatore

Overall dimensions
KV 5,5-7,5-10 270LT
with dryer

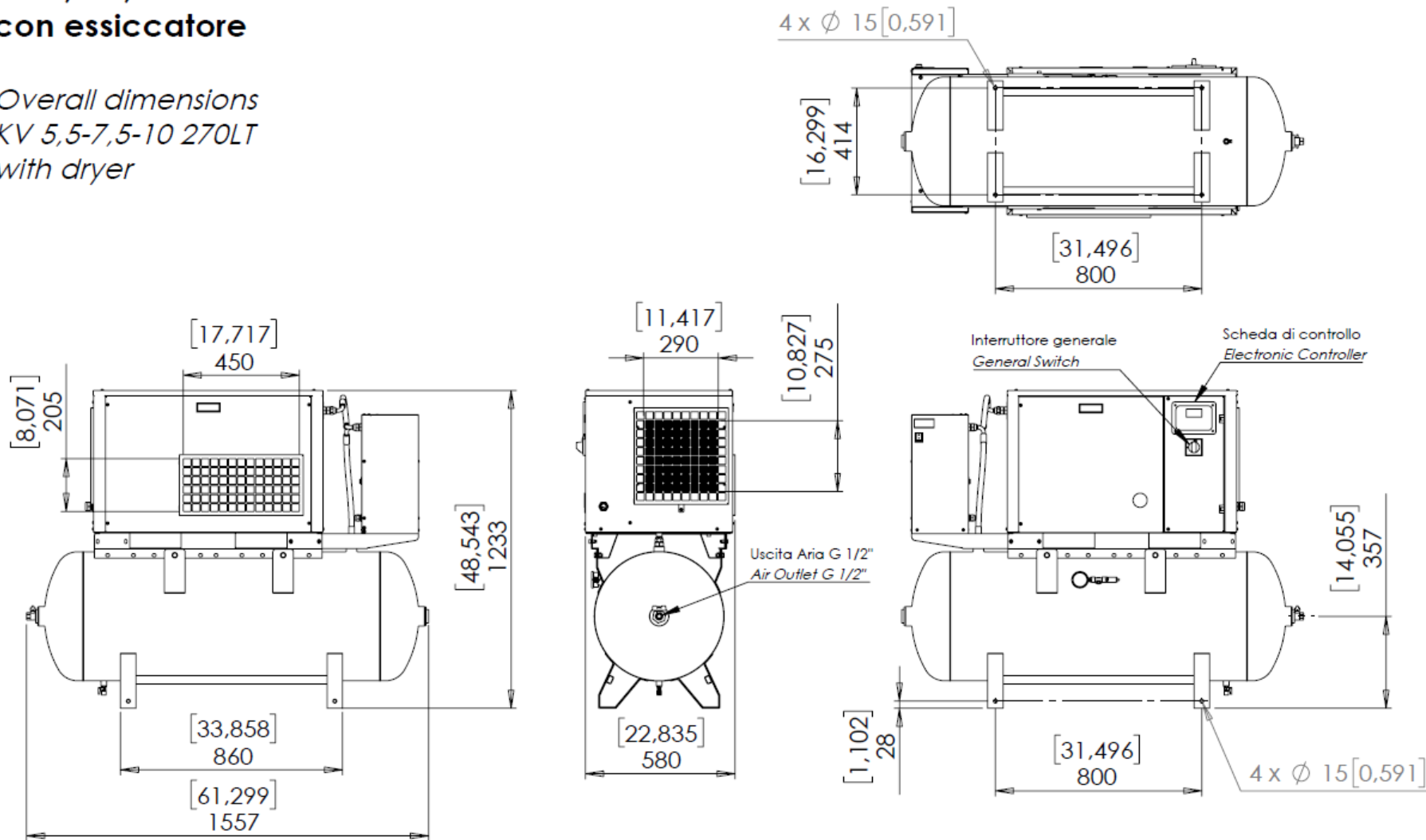

TIPO TYPE	Dimensioni di ingombro Overall dimensions	CODICE CODE	KV 5,5-7,5-10	DATA DATE	07/2022	REVISIONE REVISION	00
--------------	--	----------------	---------------	--------------	---------	-----------------------	----

Dimensioni di ingombro KV 5,5-7,5-10 500LT

Overall dimensions
KV 5,5-7,5-10 500LT

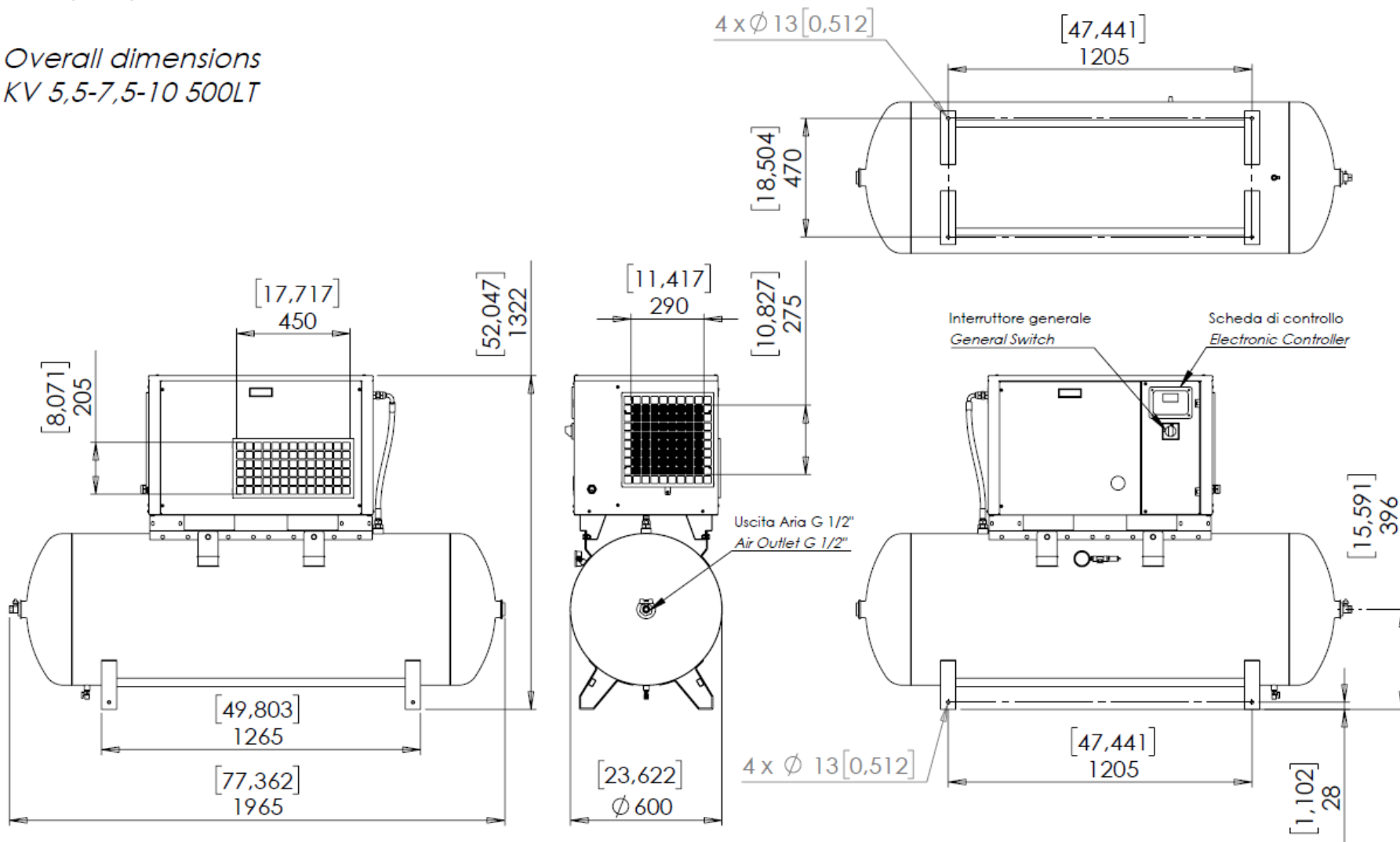

TIPO TYPE	Dimensioni di ingombro Overall dimensions	CODICE CODE	KV 5,5-7,5-10	DATA DATE	07/2022	REVISIONE REVISION	00
--------------	--	----------------	---------------	--------------	---------	-----------------------	----

Dimensioni di ingombro KV 5,5-7,5-10 500LT con essiccatore

Overall dimensions
KV 5,5-7,5-10 500LT
with dryer

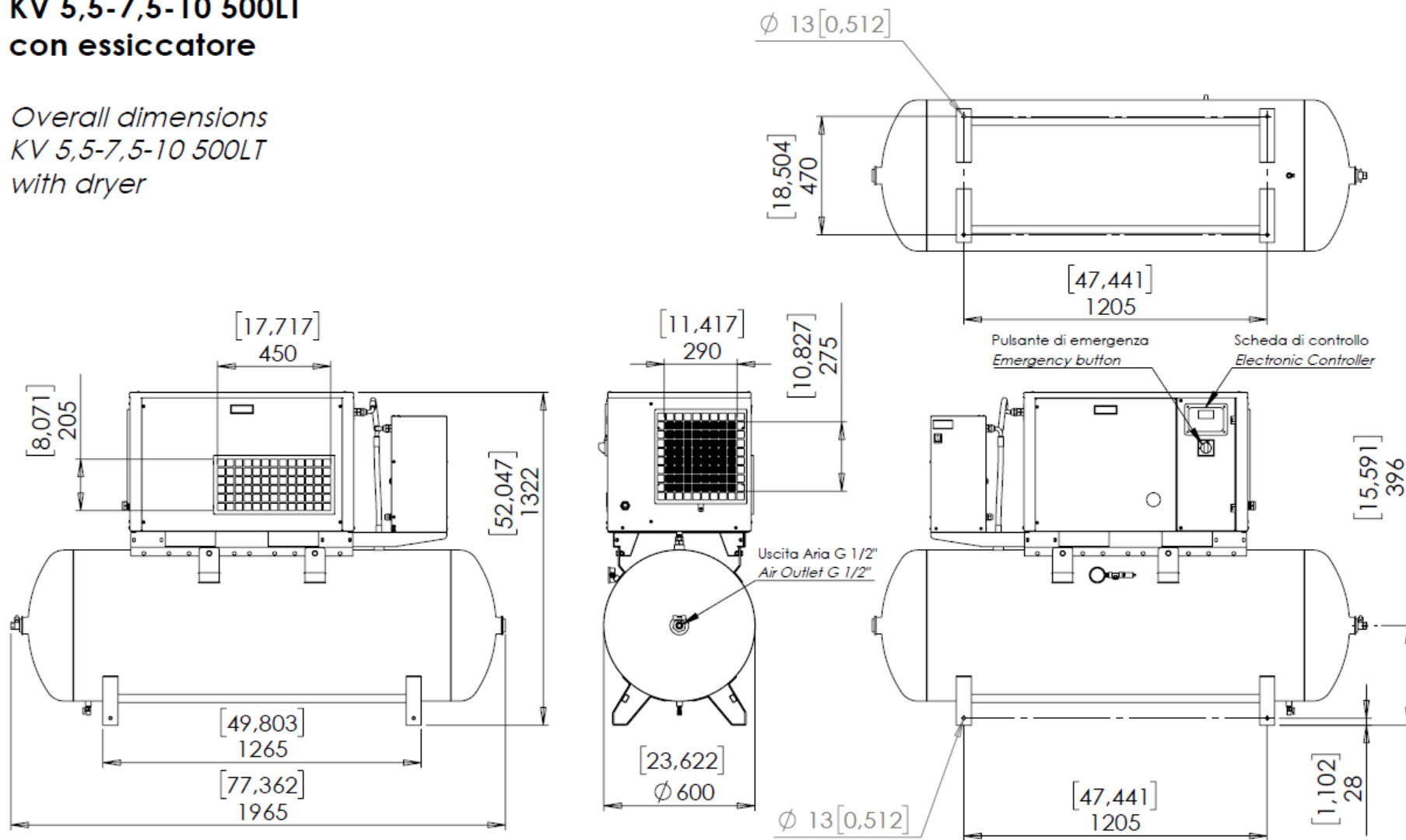

TIPO TYPE	Dimensioni di ingombro Overall dimensions	CODICE CODE	KV 5,5-7,5-10	DATA DATE	07/2022	REVISIONE REVISION	00
--------------	--	----------------	---------------	--------------	---------	-----------------------	----

Dimensioni di ingombro KV 15-20

Overall dimensions
KV 15-20

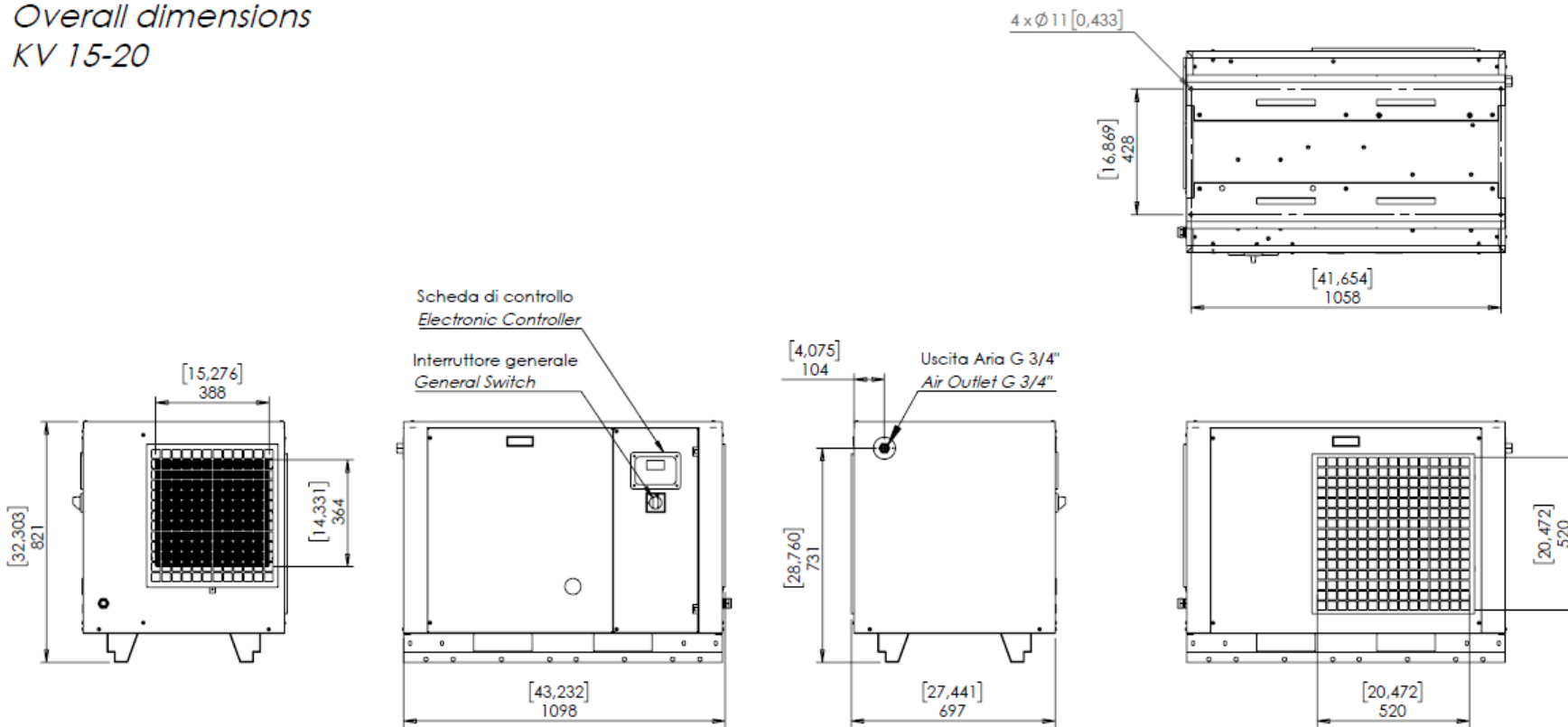

TIPO TYPE	Dimensioni di ingombro Overall dimensions	CODICE CODE	KV 15-20	DATA DATE	09/2022	REVISIONE REVISION	00
--------------	---	----------------	-----------------	--------------	---------	-----------------------	----

Dimensioni di ingombro KV 15-20 con essiccatore

Overall dimensions
KV 15-20 with dryer

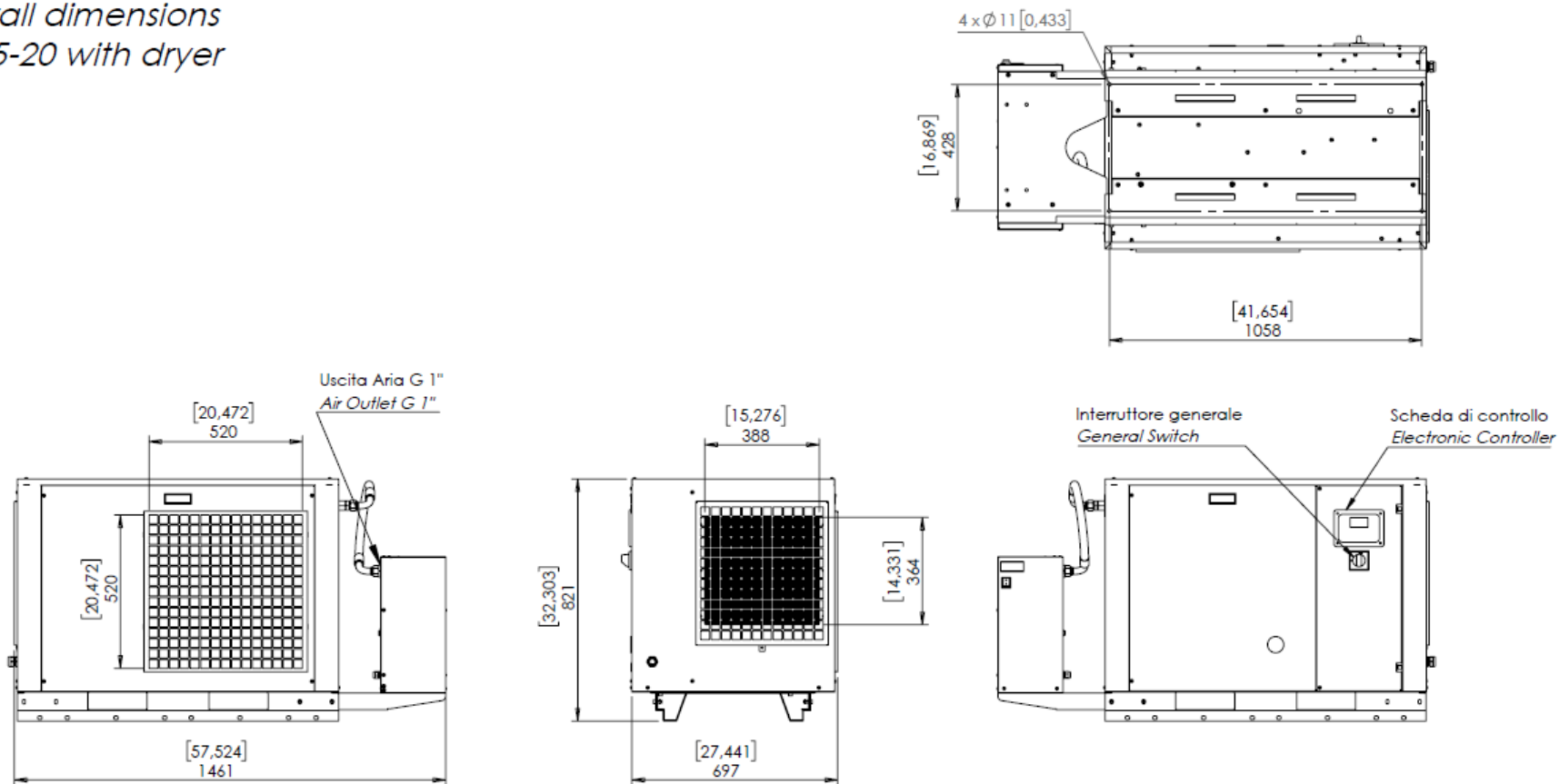

TIPO TYPE	Dimensioni di ingombro Overall dimensions	CODICE CODE	KV 15-20	DATA DATE	09/2022	REVISIONE REVISION	00
--------------	--	----------------	----------	--------------	---------	-----------------------	----

Dimensioni di ingombro KV 15-20 270LT

Overall dimensions
KV 15-20 270LT

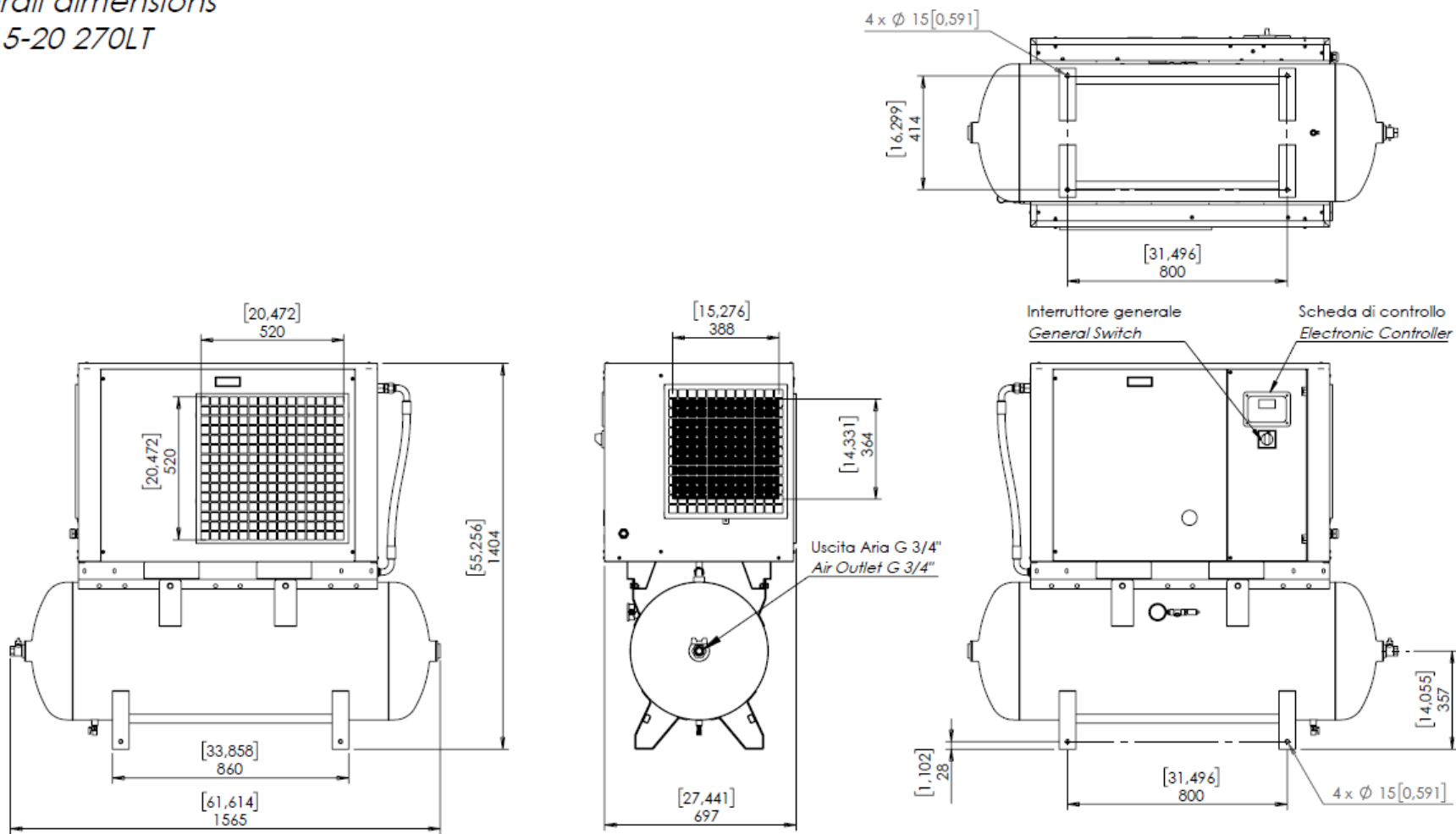

TIPO TYPE	Dimensioni di ingombro Overall dimensions	CODICE CODE	KV 15-20	DATA DATE	09/2022	REVISIONE REVISION	00
--------------	--	----------------	----------	--------------	---------	-----------------------	----

Dimensioni di ingombro KV 15-20 270LT con essiccatore

Overall dimensions
KV 15-20 270LT
with dryer

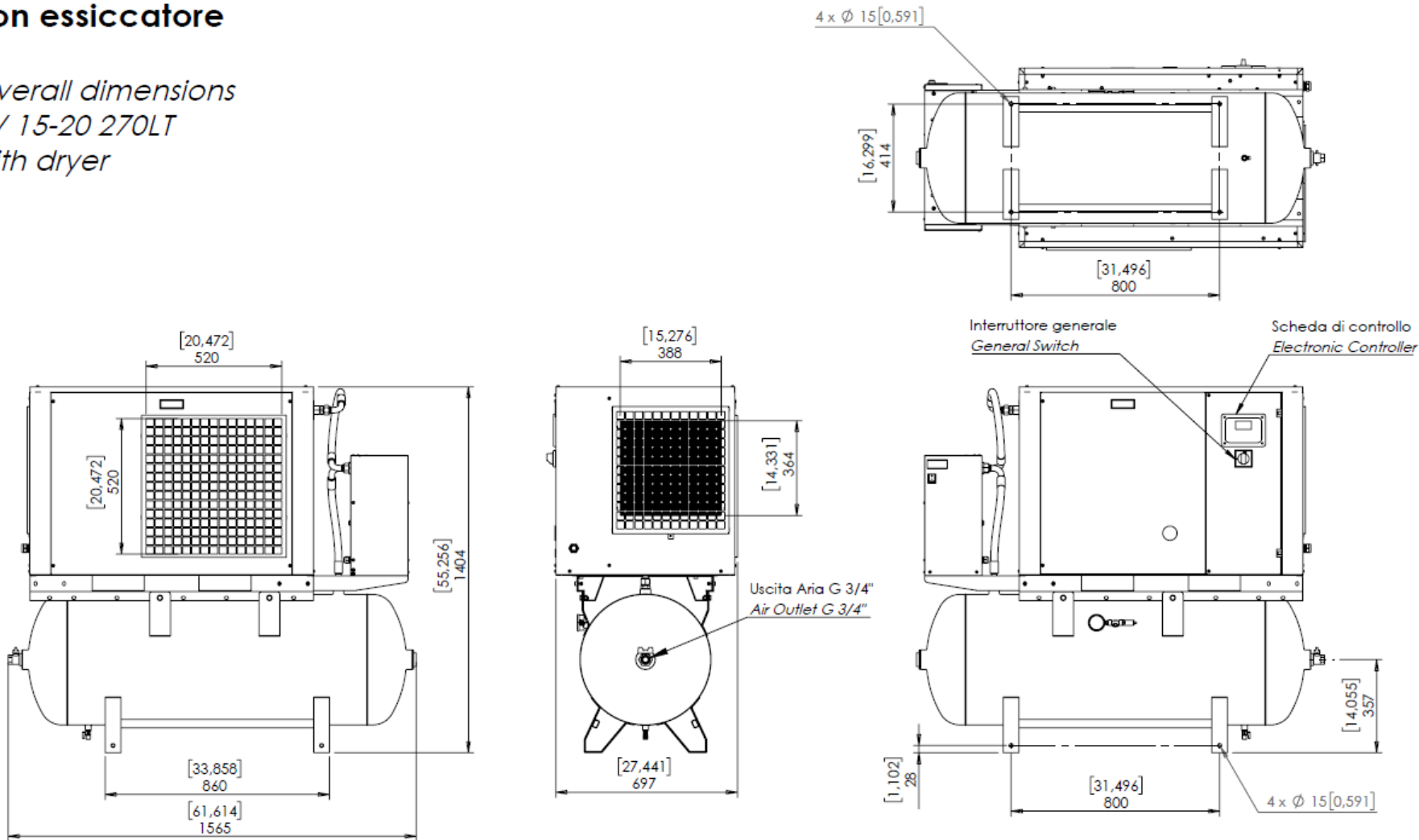

TIPO TYPE	Dimensioni di ingombro Overall dimensions	CODICE CODE	KV 15-20	DATA DATE	09/2022	REVISIONE REVISION	00
--------------	--	----------------	----------	--------------	---------	-----------------------	----

Dimensioni di ingombro KV 15-20 500LT

Overall dimensions
KV 15-20 500LT

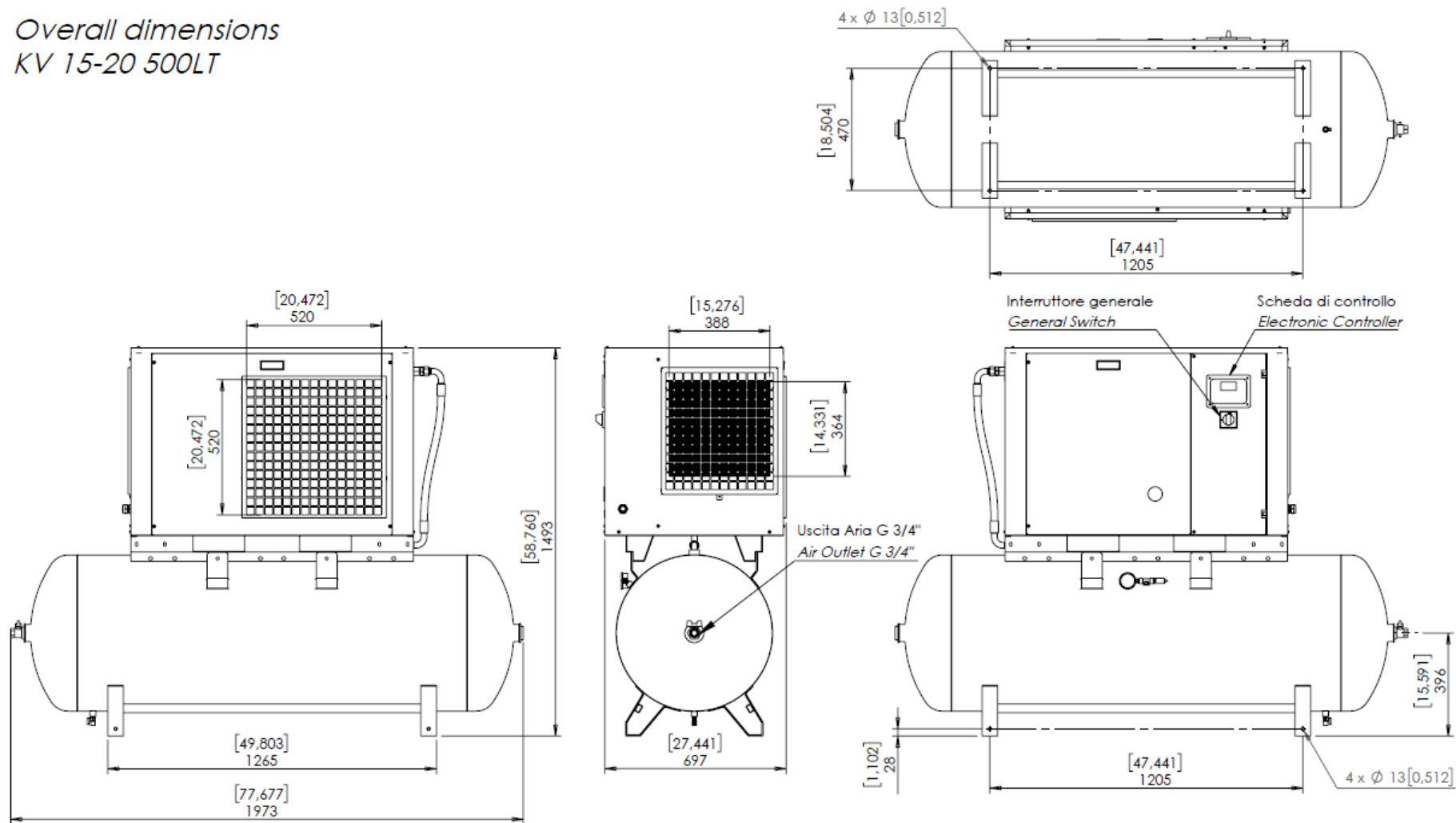

TIPO TYPE	Dimensioni di ingombro Overall dimensions	CODICE CODE	KV 15-20	DATA DATE	09/2022	REVISIONE REVISION	00
--------------	--	----------------	----------	--------------	---------	-----------------------	----

Dimensioni di ingombro
KV 15-20 500LT
con essiccatore

Overall dimensions
KV 15-20 500LT
with dryer

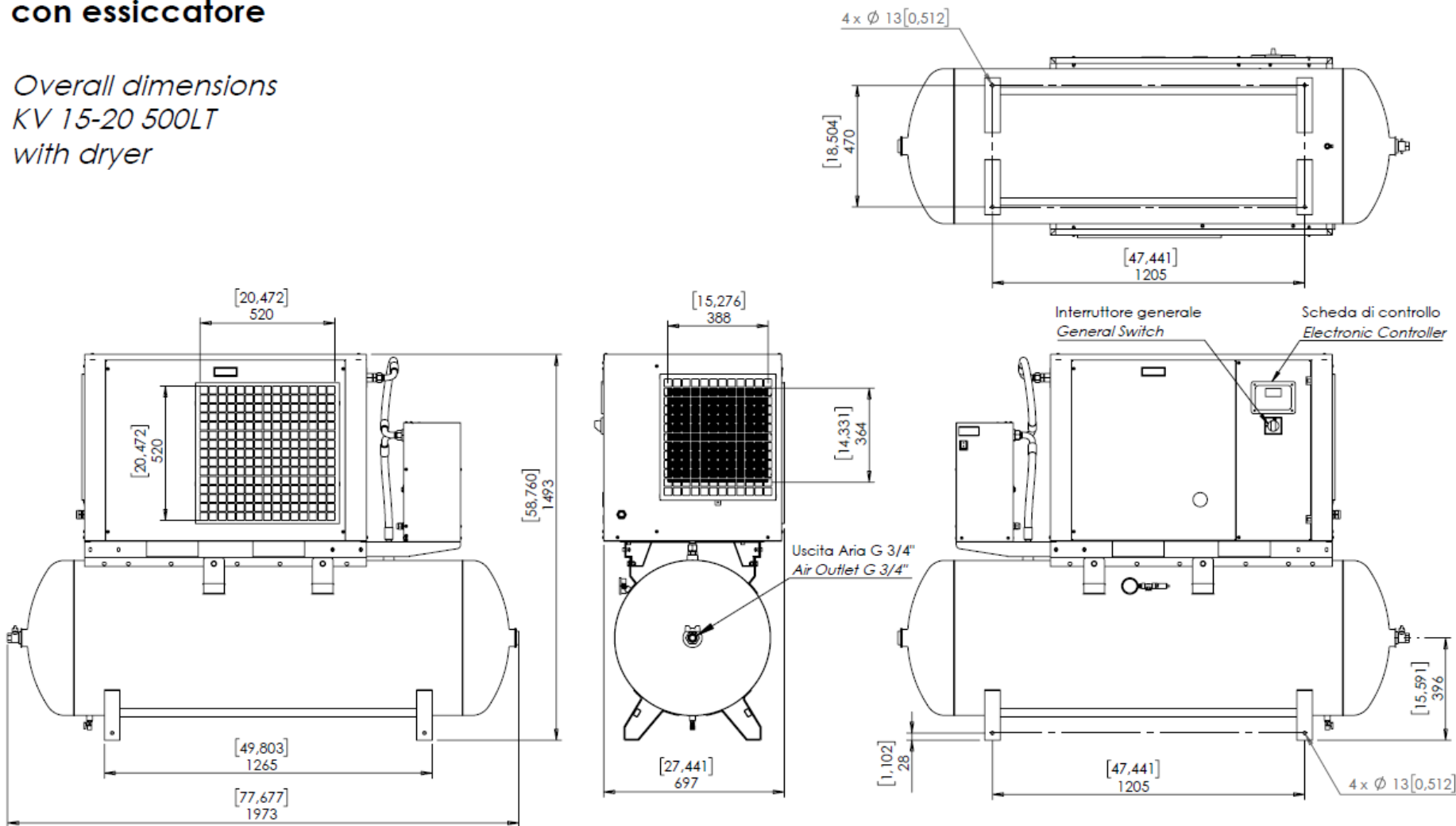

TIPO TYPE	Dimensioni di ingombro Overall dimensions	CODICE CODE	KV 15-20	DATA DATE	09/2022	REVISIONE REVISION	00
--------------	---	----------------	-----------------	--------------	---------	-----------------------	----

6 INSTALLATION



6.1 CHARACTERISTICS AND STORAGE CONDITIONS

During periods of inactivity, before being unpacked (storage), the compressor must be kept at a temperature of between +5 °C and +45 °C and in a dry place sheltered from the weather.

Once unpacked, when the unit is not going to be used (prior to start-up or when production is interrupted), the compressor should be protected with a tarpaulin to protect dust from gathering on the mechanical and electric mechanisms.

If the compressor has remained inactive for a long period of time, before starting it up again, change the oil and check function.

6.2 TRANSPORT

To ensure that the unit is protected and does not incur shipping damages, the compressor is screwed onto a wooden pallet and covered with a cardboard box.

All shipping information is printed on the compressor package (data and pictograms).

6.3 UNPACKING

When unpacking the unit, carefully check that the contents match what is indicated in the shipping documents.

The user must dispose of packaging in compliance with current national regulations.



The machine must be unpacked by qualified personnel using suitable tools.

6.4 HANDLING

The compressor is to be lifted with a fork lift truck rated for the weight of the unit.

- Check that the outside packaging is intact.
- Unpack the machine carefully.
- Check that the outside of the machine is intact.
- Dispose of the packaging in compliance with current environmental regulations.

The compressor should be handled as indicated in figures 2 and 3.

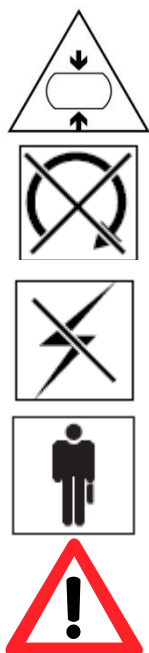

Figure 2



Figure 3

THE COMPRESSOR CAN BE LEFT ON THE PALLET WHICH MAKES SUBSEQUENT MOVEMENT EASIER.

6.5 LOCATION



Install the compressor at the site point indicated at the time the order was placed. If the unit is installed at a different site, **the manufacturer cannot be held responsible for any ensuing problems.**

Unless specified otherwise at the time the order is placed, the compressor must run normally under the environmental conditions indicated below.

The room where the compressor is installed must comply with current accident prevention standards and must meet the following requirements:

- Protected from rain and frost.
- Relatively free of dust. In time, a dusty environment can lead to damage and operating problems.
- Adequately ventilated and of such size that environmental temperature remains steady (min. 5°C, max. 45°C) when the machine is running. At the maximum admissible environmental temperature (45°C) and with a relative humidity above 80% machine performance can reduce. Likewise, machine performance may be reduced when the unit is installed at an altitude of 1000 m above sea level.
- If hot air exhaust is inadequate, install exhaust fans at the highest position possible (see figure 4).
- Lighting: the compressor is built considering current standards and seeking to reduce shadow zones to the barest minimum, thus facilitating operator intervention; as the compressor room lighting system is deemed important for personnel safety, there must not be any shadows, glaring lights or stroboscopic effects due to the lighting.
- Potentially explosive and/or flammable atmospheres: in its standard configuration, the compressor is not designed to work in environments where there is the risk of explosion and/or fire;

6.6 FOUNDATIONS

Once the position for the compressor has been identified, check that it is set on a flat surface. The machine does not require foundations or any specific preparation of the support surface (foundation works).



CAUTION!!

Do not insert any check valves between the compressor and the tank.

- **The ducting must not exceed 3 metres in length; if this proves necessary, install a fan on the outlet side (see figure 4).**
- **The ducts must maintain a section that generates a maximum pressure loss of 40 Pa.**
- **Condensation must not be discharged into the environment or into the sewers. The well must be fit with a valve and removable container, or it must be connected to a special unit to separate the air from the water.**

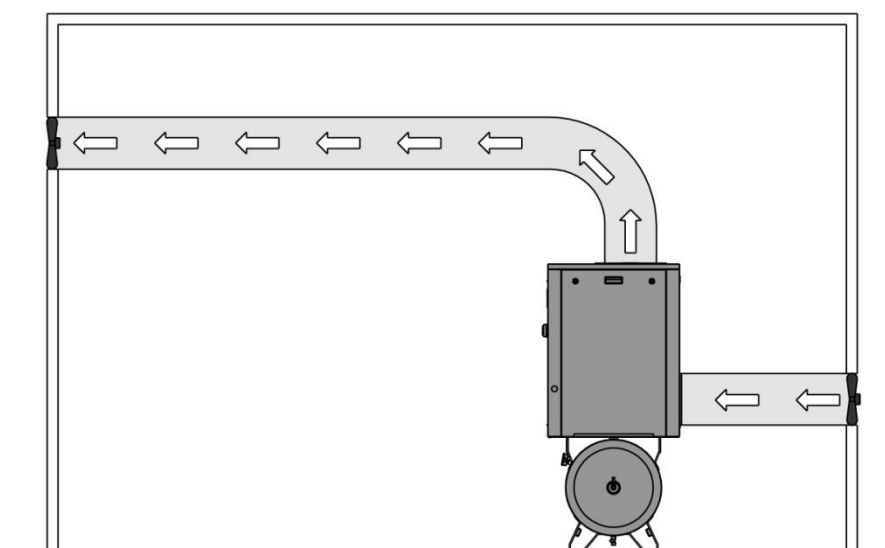
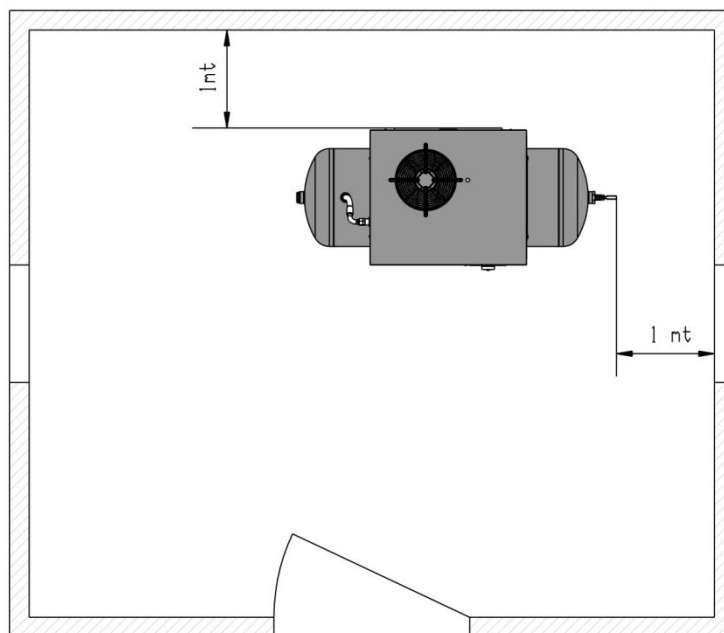

Figure 4

6.7 CONNECTION AND START-UP



6.7.1 GENERAL WARNINGS

When starting up the unit for the first time, make certain that:

- The power supply matches the requirements indicated on the label.
- The wall-mounted general switch is proportioned according to the indications in the technical data table (see chapter 6.7.3.3).
- The oil is at the correct level (see chapter 9.1.6).
- The electrical connections have been made using cables of adequate section (see chapter 6.7.3.2)

CAUTION!



Carefully comply with the SAFETY WARNINGS regarding use of the machine.



For the European market the compressors and tanks are built according to the Directives in force mentioned in the declaration of conformity attached to the machine



Check the label on the compressor and at the beginning of this manual for indication of your model.

6.7.2 CONNECTING THE POWER SUPPLY CORD OF THE COMPRESSOR



- 1- Insert the power supply cord through the cable seal and run it as indicated by the red arrow in figure 5.

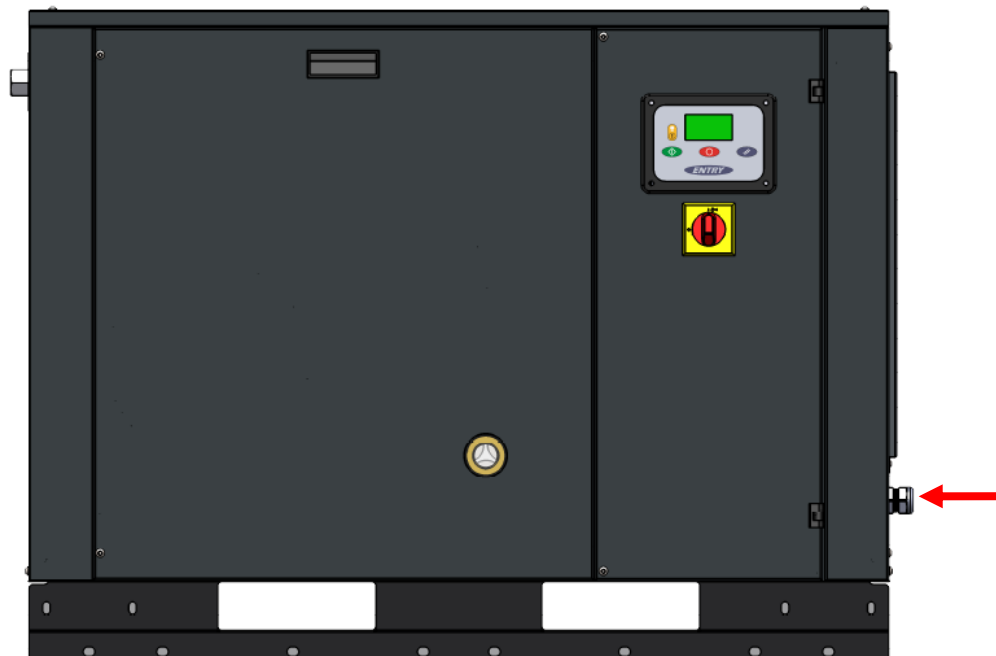

Figure 5

- 2- Connect L1 L2 L3 to the disconnecting switch as indicated in figure 6.

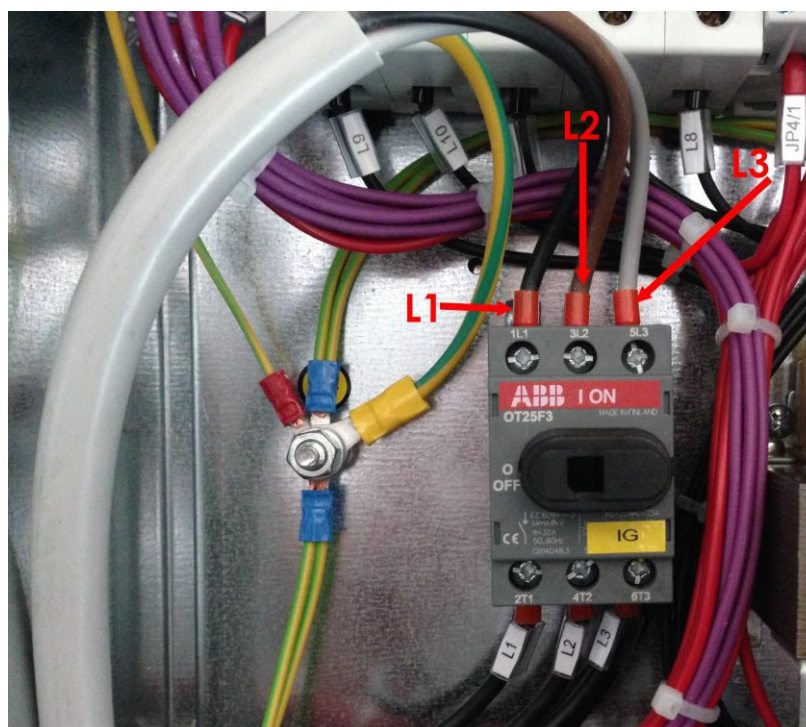

Figure 6

6.7.3 CONNECTING THE COMPRESSOR TO THE ELECTRICAL POWER SUPPLY



The machine is connected to the electrical power network by the customer, at his own expense and responsibility, using qualified personnel and in compliance with accident prevention standard EN 60204

6.7.3.1 Ground connection

To protect the operator from electric shocks, the compressor must be grounded during use. The ground connection must be carried out by a qualified technician or by a specialized service centre. The ground connection on the compressor power supply cord must be connected only to the terminal on the compressor itself.

Before replacing the plug of the power supply cord, make certain that the ground is connected.

6.7.3.2 Sizing of the Power Supply Cable

Never use damaged cables. Always make certain that the cable is in good condition. Use only cables with an adequate size to the compressor's maximum current absorption. If the cable is too thin, there will be a drop in voltage, power loss and the unit will overheat. The cable section must be proportioned to the cable length and to the ambient temperature of the room where the cables are used. The values indicated below refer to an ambient temperature within 40°C:

KW	220/240 V 50/60 Hz	380/415 V 50/60 Hz
4	4 mm ²	2.5 mm ²
5.5	4 mm ²	2.5 mm ²
7.5	6 mm ²	4 mm ²
11	10 mm ²	6 mm ²
15	16 mm ²	10 mm ²



Avoid all risks of electric discharges. Never use the compressor if the power supply cord or extension cord are damaged. Check the electrical cables regularly. Never use the compressor in dangerous environments where electrical discharges can occur.



Installation must be performed by a qualified technician.





6.7.3.3 Fuses and circuit breaker

It is advisable to install the outlet, the circuit breaker and fuses near the compressor (not more than 3 metres away). The circuit breaker and fuses must have the characteristics indicated in the table below:

KW	Nominal tension 220/240 V		Nominal tension 380/415 V	
	Thermomagnetic	Fuse	Thermomagnetic	Fuse
4	20 A	20 aM	12 A	12 aM
5.5	25 A	25 aM	16 A	16 aM
7.5	40 A	40 aM	25 A	25 aM
11	50 A	50 aM	32 A	32 aM
15	63 A	63 aM	40 A	40 aM

The values refer to **AM** (time-lag) fuses.
The values refer to "**D-type**" switches.

- Always check that the installed power, in kW, is at least double the absorbed power rating of the electric motor.
- The line voltage must match the electrical parameters indicated on the machine label; the acceptable variation must not exceed 6%.
- The power supply plug must not be used as a switch; it must be plugged into a power outlet controlled by an adequate differential switch (circuit breaker).



Never use the ground in place of the neutral. Ground connection must be performed in compliance with accident prevention standards (EN 60204). Make certain that the line voltage matches that required for good compressor function.

6.7.4 INFORMATION ON THERMAL RELAY CALIBRATION



CAUTION!!

Turn off power to the compressor before performing any work on the electric box. To ensure that the compressor will operate properly at full continuous load at maximum working pressure, make certain that the room temperature does not exceed + 45°C. Make certain that the compressor working temperature remains below the set cut-off value - SEE PARAMETER ON ELECTRICAL CONTROLLER (T. MAX). Check the air/oil exchanger and keep it clean. For problems related to high environmental temperature, we recommend using special oils rated for high temperatures and contact an Authorized Service Centre to solve the problem.

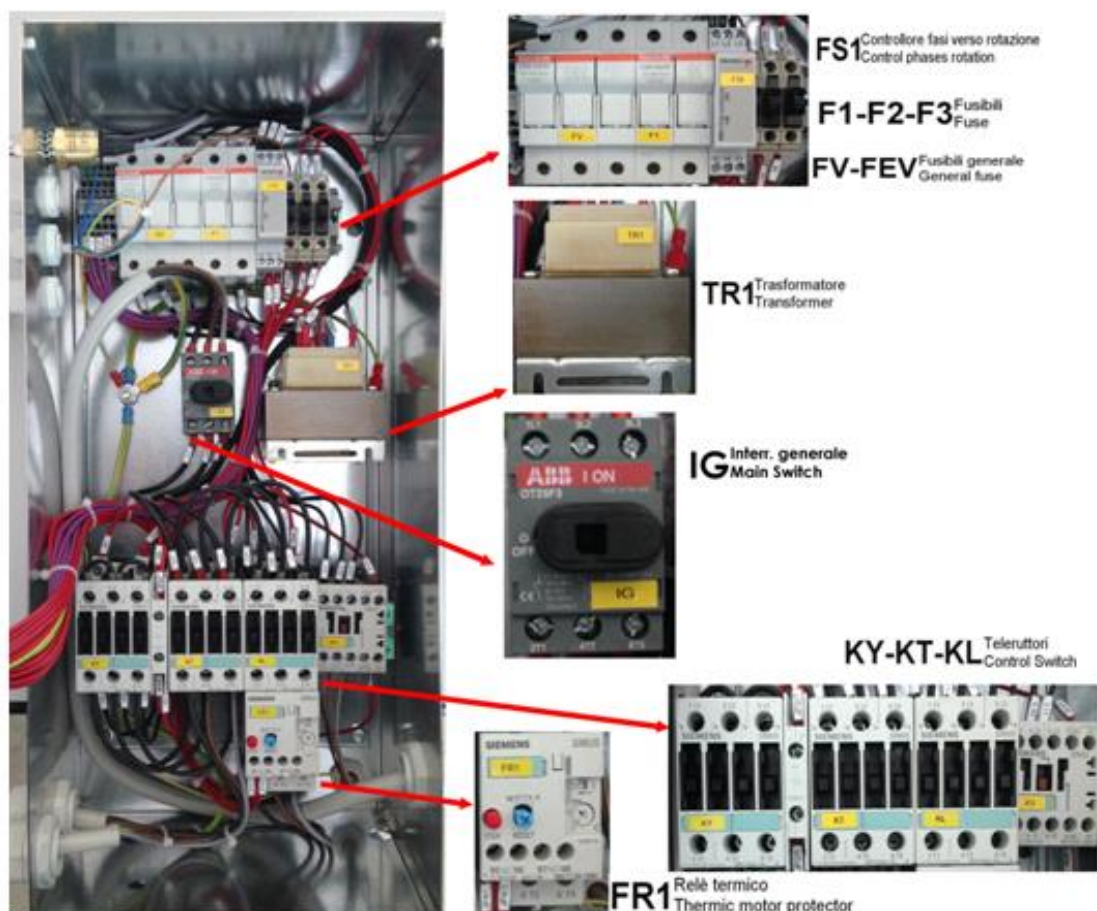

Adjustment of thermal relay **FR1** must reflect the values indicated in the table below; if the thermal relay trips, check absorption and voltage at the line terminals during operation and check the power connections inside the electrical panel and on the motor terminals. The thermal relay **FR1** is set as indicated in the table below:

- For models with remote start-up:

kW	Nominal tension 380/415V-3ph	Nominal tension 220/240V-3ph
4	5 A	9 A
5.5	7 A	13 A
7.5	9 A	18 A
11	13 A	25 A
15	17 A	32 A

6.7.5 WIRING DIAGRAM

The specific scheme of the machine is contained in the specific electric box.

6.7.6 COMPRESSOR CONNECTION TO ELECTRICAL POWER SUPPLY



Be sure to use the pneumatic hoses for air compressed with features and cross section appropriate to the compressor. Do not repair a faulty hose, but proceed with the replacement.

Connect the compressor to the pneumatic system using the special female connection on the compressor and indicated in the image. It is recommended to use a pipe with a diameter equal to or greater than the compressor outlet. To avoid malfunctions in the pressure control, any shut-off and check valves must be installed near the tank / manifold.

Attention: **DO NOT INSTALL IN IMMEDIATE** vicinity of the compressor.

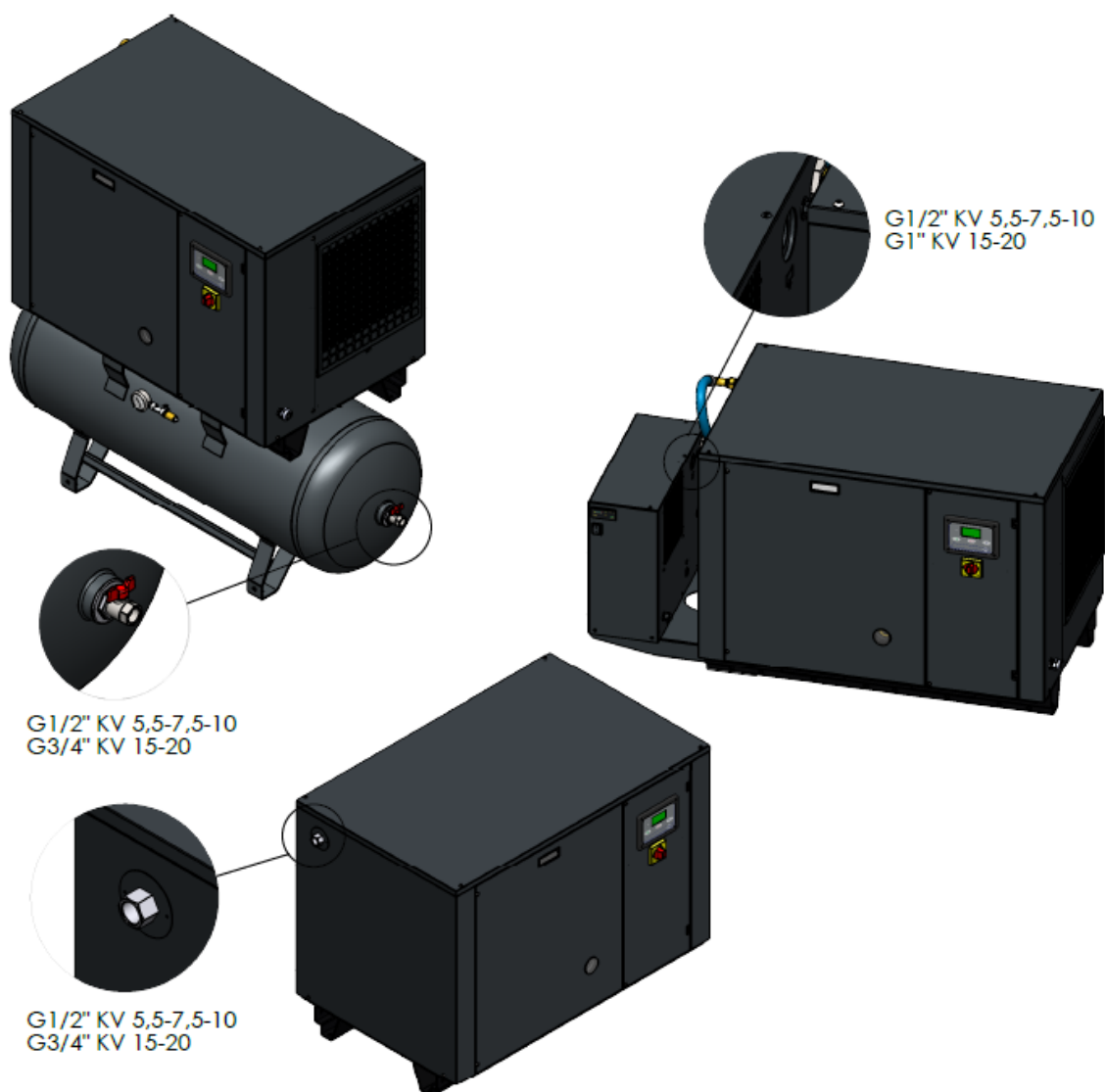

A check valve is already installed inside the compressor.

6.7.7 FIRST START-UP



The first compressor start up (operational testing) must be performed by a qualified technician. Remember, for the technical warranty to be valid, that the registered test report (R.C.R.) attached to the documentation must be filled out (see notes on sales clauses).

After having taken all compressor assembly steps, prepare the machine for first start-up.

Every time the compressor is turned on, the control panel runs a check on the power supply line phases to ensure that the screw assembly is turning in the right direction.

- If the power supply line phases have been correctly positioned, the screw will turn as indicated by the arrow in **figure 9**.
- If the power supply line phases are not positioned correctly, the machine blocked alarm will appear on the panel.
In this case, switch connection of the two power supply phases on the line and start up the compressor again.

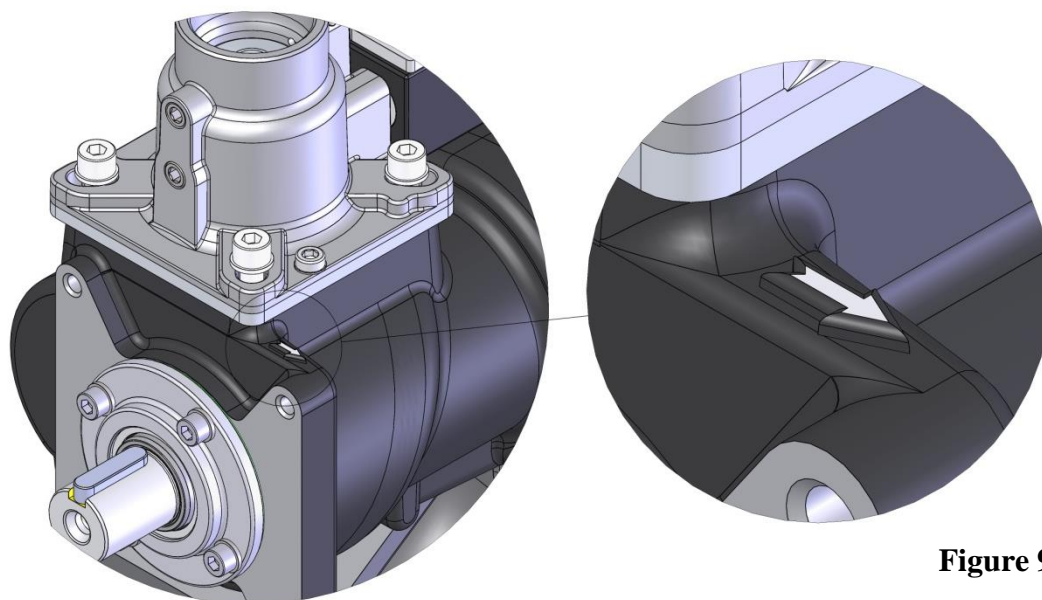

Figure 9



CAUTION!

Reverse screw rotation turning opposite the direction indicated by the arrow in relief on the body of the machine (see figure 9) can damage the screw assembly!



CAUTION!

If the electric motor is replaced, when it is started up once more, always visually inspect the unit to ensure that the screw is turning in the right direction.



CAUTION!

Always carefully follow the SAFETY WARNINGS regarding use of the machine. This is extremely important.

6.8 CLEANING AND DISINFECTION

Keeping the installation site and the compressor clean is essential to good machine operation and keeps operating and maintenance costs down (see chap. 6.5).

Installation site and compressor disinfection is essential to guarantee good air quality in the compressor room and in the area where the compressed air is used (workshop).

6.9 REINSTALLATION AND REUSE

Reinstallation and reuse of the machine must be performed by qualified personnel and only after checking the condition of the machine itself.

The points indicated in the previous chapters hold here as well.

6.10 DEMOLITION AND DISPOSAL



If the compressor is to be demolished and disposed of, this must be performed in compliance with current regulations.

Always contact an authorized waste disposal and recycling facility.

7 OPERATION AND USE

7.1 DESCRIPTION OF THE OPERATION

For the machine functions, see chap. 3.

7.2 RANGE OF APPLICATIONS

The machine is suited to all those applications requiring compressed air at the flow rate and pressure outlined in the technical data sheet (see chap. 4).

7.3 PROPER AND IMPROPER USE

CAUTION!



The compressor is designed and built solely to produce compressed air. The manufacturer is relieved of any responsibility for risks ensuing from any other use.

CAUTION!



Any use of the compressor that differs from the agreements made at the time of purchase relieves the manufacturer of any responsibility for ensuing injury or property damage or damage to the machine itself.

CAUTION!



The electrical system cannot be used in flame-proof areas and with flammable products.

CAUTION!



Never direct air jet toward persons or animals. Never use compressed air for breathing or in production processes where the air produced is in direct contact with foodstuffs, unless previously treated and filtered.

7.4 OPERATING AND ENVIRONMENTAL LIMITS

The operating and environmental limits are indicated in the table containing the technical data and characteristics (see chap.4).

7.5 WORKSTATION AND DANGEROUS AREAS







During normal operation of the machine, the operator works on the side where the electronic controller is located. Once correctly connected to the electrical and pneumatic system, the machine is completely protected on the outside and thus there are no dangerous areas accessible during normal operation.

When scheduled and unscheduled maintenance is performed, the machine is completely open. These operations must be performed under safe conditions by qualified personnel (see chap. 9).

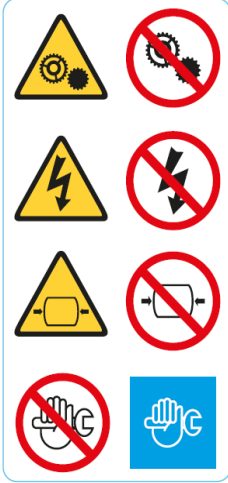
7.6 SAFETY DEVICES AND SIGNALS

The machine is equipped with safety devices and signals to prevent situations dangerous for the operator and the machine itself.

These devices and signals come in the form of labels placed at dangerous points, and alarms that are displayed on the electronic controller.

SIGNAL	MEANING
	<p>ATTENTION: Do not perform any maintenance operations on this machine before:</p> <ul style="list-style-type: none"> • having stopped all moving parts • have disconnected the power supply • have completely discharged the pressurized air. <p>Maintenance and repair must be performed by specialized and authorized personnel!</p>
	<p>ATTENTION: Hot surface</p>
	<p>ATTENTION: Component or pressurized system</p>
	<p>ATTENTION: Risk of electric shock</p>
	<p>ATTENTION: Check the oil level with the machine stopped</p>
	<p>ATTENTION: For maintenance consult the user manual</p>
	<p>ATTENTION: Do not use to turn off the compressor, use only for technical intervention</p>

7.6.1 POSITION OF THE LABELS

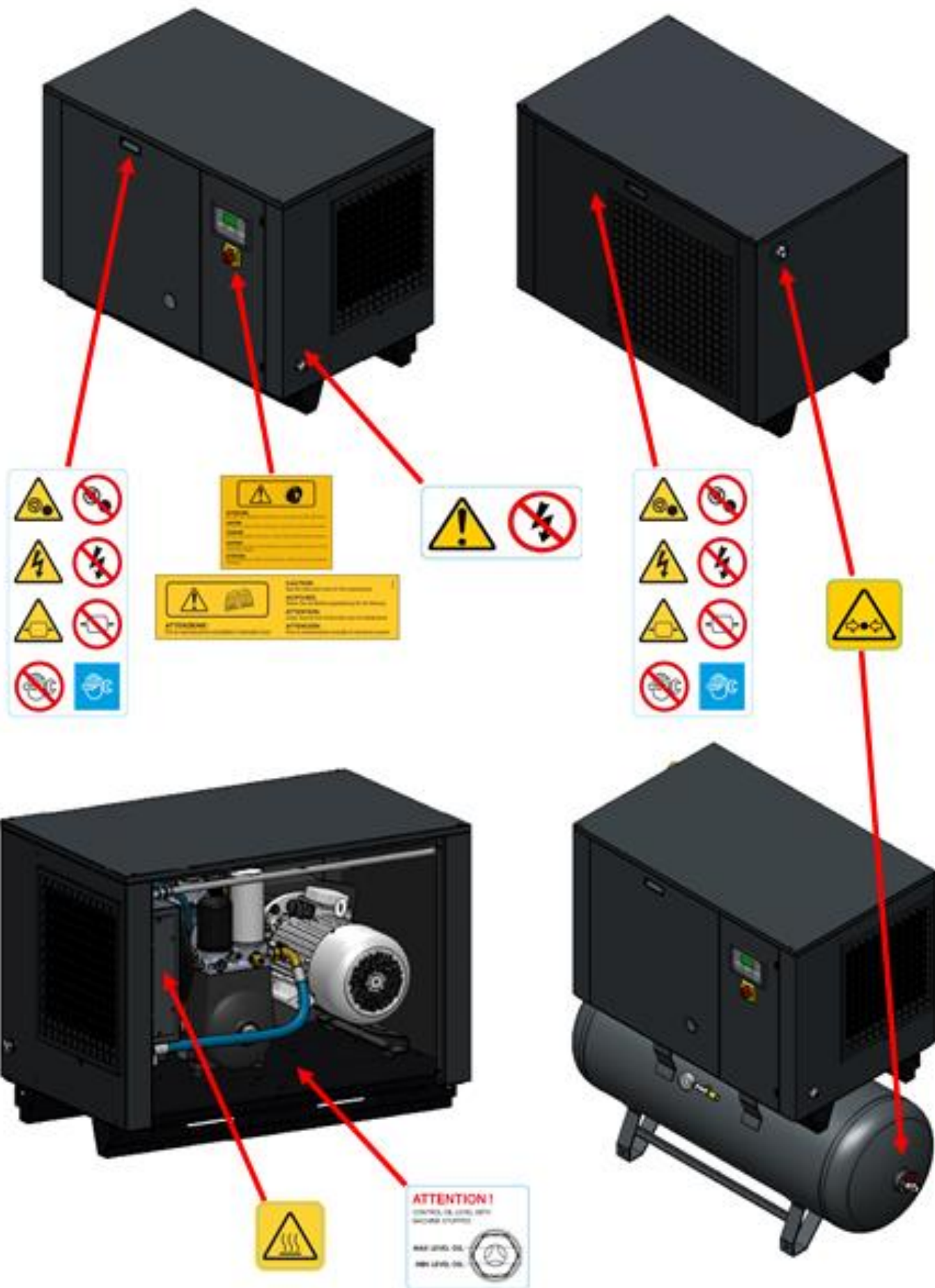

7.7 PERSONAL PROTECTIVE EQUIPMENT, SAFE WORKING PROCEDURES AND TRAINING

Use of the compressor does not require any PPE.

Our technical services department is at your disposal, ready to provide any information you may need and to help you resolve any problems that may arise.

For any information, please log onto our website www.italyco.net

For any clarifications you may require, contact our **customer services department** or your area **retailer**.



7.8 COMPRESSOR LUBRICATION

7.8.1 GENERAL RECOMMENDATIONS

CAUTION!



Before performing any operation involving draining or topping up compressor oil, unplug the compressor and wait until the system has reached atmospheric pressure. Use adequate protection when handling lubricants.

We recommend a lubricant compatible with the ISO VG 46 oil (mineral-based oil) used during testing. The pour point must be at least $-8+10^{\circ}\text{C}$ and the flash point higher than $+200^{\circ}\text{C}$.

Oilscrew plus 46

For use of incompatible oils, follow the procedure described in chapter 7.8.2



Never mix different types of oil

We recommend using oil with a VG32 rating for cold climates and VG68 for tropical climates.

Before starting up compressors without oil, feed **approximately 0.1 l** of lubricant in through the regulator intake opening while keeping the suction valve shutter lowered and manually turning the screw rotors in the right direction.



CAUTION!



When lowering the suction valve shutter be careful not to damage the throttle valve O-ring.

Feed the mineral-based lubricant into the oil tank using the special top-up hole and fill until the right level is read on the window. The correct quantity of oil is indicated in the table chap. 4



Start up the compressor, initially switching it on and off sequentially and quickly and then starting it up.





Once initially filled with oil, turn off the compressor, vent the pressure and, if necessary, top up the lubricant from the top-up hole until the right level is read on the window.







7.8.2 USING THE COMPRESSOR WITH SYNTHETIC OILS





If you wish to use a synthetic lubricant, carefully follow the procedure below.

- Drain all mineral oil from the compressor circuit using the oil drain cock.

- Feed the synthetic lubricant or detergent oil into the oil tank through the top-up hole and fill up to the correct level.

- Before starting up the compressor or the first time after installation, feed **approximately 0.1 l** of lubricant in through the regulator intake opening while keeping the suction valve shutter lowered and manually turning the screw rotors in the right direction.

 **CAUTION!**
When lowering the suction valve shutter be careful not to damage the throttle valve O-ring.

- Start up the compressor, initially switching it on and off sequentially and quickly and then starting it up.

- Then turn off the compressor and drain all lubricant from the system using the cock.

- Through the oil top-up hole, feed new synthetic lubricant in until it reaches the set level; then start up the compressor and run it steady for about 10 minutes.

- Turn off the compressor, vent the pressure and, if necessary, top up by feeding the lubricant through the top-up hole until the right level is read on the window.

 **CAUTION!**
If the above-mentioned “washing” cycle is not performed, the mixing of incompatible lubricants may cause problems in lubrication. Use adequate protection when handling lubricants.
Dispose of mineral lubricants in compliance with current environmental regulations.

 **CAUTION!**
Before performing any operation involving draining or topping up compressor oil, unplug the compressor and wait until the system has reached atmospheric pressure.
Use adequate protection when handling lubricants.



8 INSTRUCTIONS FOR THE USER

ELECTRONIC CONTROLLER

ENTRY



8.1 BUTTON LAYOUT

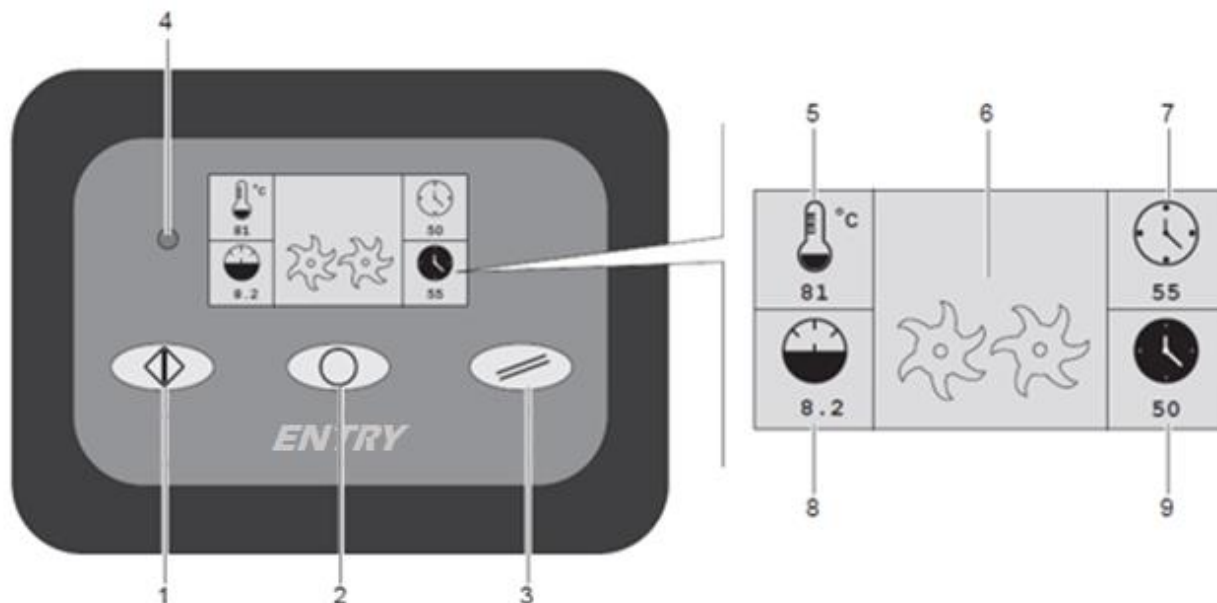

Control panel

- 1 - START button
- 2 - STOP button
- 3 - RESET button
- 4 - Alarm Led

Display

- 5 - Air-end delivery temperature
- 6 - Compressor state
- 7 - Working hours (total)
- 8 - Pressure
- 9 - Working hours (duty)

8.2 DESCRIPTION OF THE OPERATIONS TO BE PERFORMED

MAIN PAGE

Compressor ON
(rotors moving)

Compressor is charging
(rotors moving)

Idle running time
(rotors moving + countdown)

OR

Restart time
(rotors flashing + countdown)

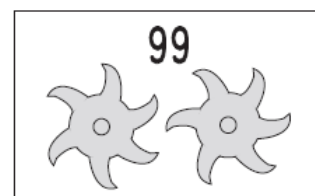
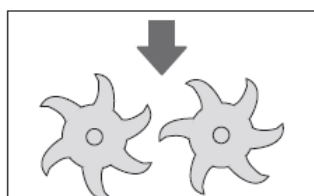
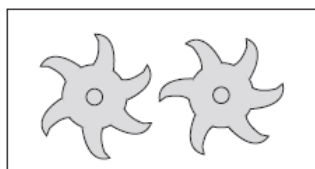

8.3 PROGRAMMING KEYPAD



REMAINING HOURS TO MAINTENANCE

Push button  for 5 seconds to see **remaining hours to maintenance**.

If time is already expired, a negative number will be shown (e.i -3) alternately to the compressor status.



USER MENU - SETTING

Push button  and  together for at least 5 seconds to enter the **Setting parameters Area**.

The setting menus are accessible to different levels only entering a password

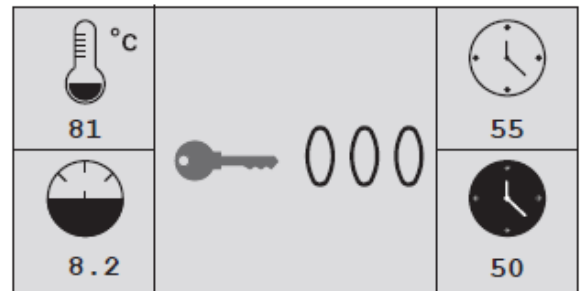

MINIMUM PRESSURE setting (*)

Min = 5,5 bar / 80 psi - Max.15 bar / 218 psi

N.B display does not show comma/dot:

055 = 5,5 bar (as shown on the example)

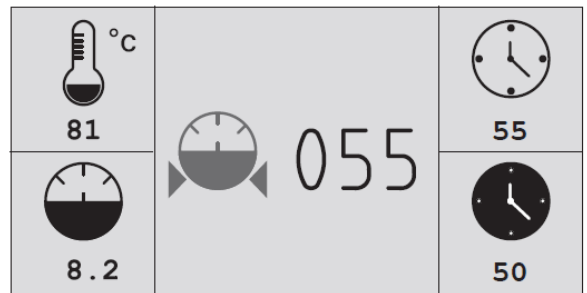

MAXIMUM PRESSURE setting (*)

Min = 6 bar / 87 psi - Max.15,5 bar / 225 psi

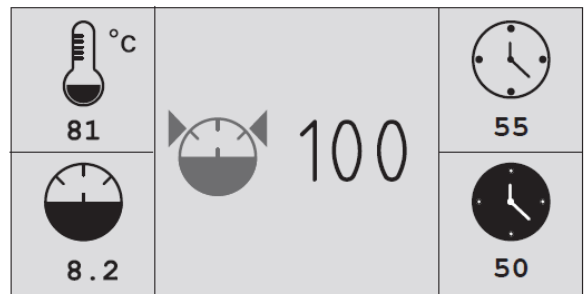

N.B display does not show comma/dot:

100 = 10,0 bar (as shown on the example)



TO MODIFY SETTING

Push  (value is flashing) :

Push buttons  and  to change values , and  to confirm.

By pushing  you can confirm setting and move forward.

If you don't want to change the setting press  to move forward, or  to move backward.

At the end of the menus, display will show "OUT", press  to exit and go back to the compressor status .



During the setting procedure, if any button is not pushed for 60 seconds, the control panel will exit automatically.

8.4 ALARMS LIST

WHEN THESE SIMBOLS ARE FLASHING ALARM IS ON

TEMPERATURE SENSOR broken or disconnected
Compressor does not start or stops.

Press  to reset.

Alarm can be reset only once the problem is solved.

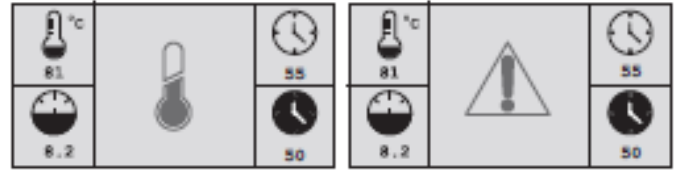

HIGH TEMPERATURE (> 105°C/221°F)

Compressor stops.

Press  to reset, only when the temperature is lowered at least 10°C.

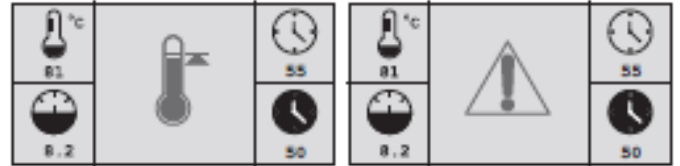

LOW TEMPERATURE (< -5°C/23°F)

Compressor does not start or stops.

Press  to reset, only if the temperature is +10°C / 50°F or more.

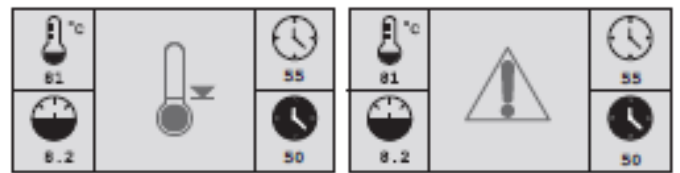

MOTOR WRONG SENSE OF ROTATION or EMERGENCY STOP PRESSED

Compressor does not start or stops.

Press  to reset.

Alarm can be reset only once the problem is solved.

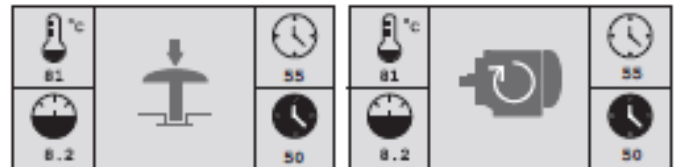

MOTOR THERMAL PROTECTION

Compressor stops.

Press  to reset.

Alarm can be reset only once the motor temperature reaches acceptable value.

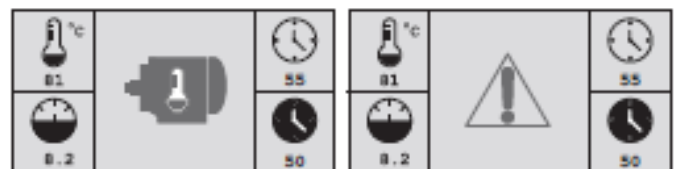

HIGH PRESSURE or PRESSURE SENSOR broken or disconnected (*)
Compressor does not start or stops.

Press  to reset.

Alarm can be reset only once the problem is solved.

(*)To be ignored for version with pressure switch.

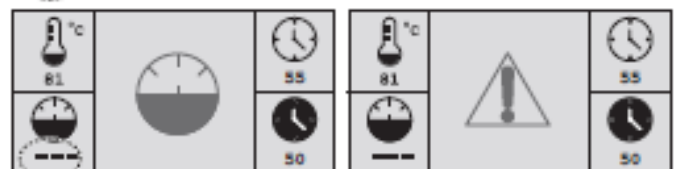
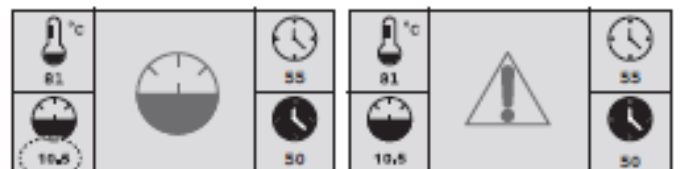

MAINTENANCE TIME ESPIRED

Compressor keep on working.

Alarm can be reset only after maintenance is done.

Contact your local after sale service.



8.5 START, STOP AND EMERGENCY STOP FUNCTIONS

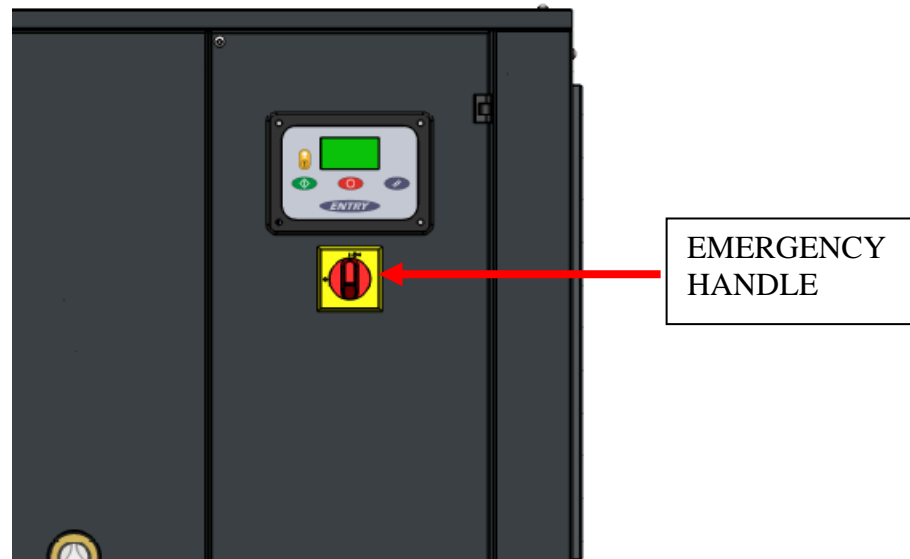

Figure 11

START See chap. 8.1

STOP See chap. 8.1

EMERGENCY STOP

Achieved by pressing the **Emergency handle** (see figure).

This mechanically engaged handle immediately stops the compressor if an emergency arises. When this handle is engaged, the compressor cannot perform any operation.

8.6 RESET CONDITIONS

To reset emergency handle functions, turn the handle clockwise; this will enable the compressor to start.

9 COMPRESSOR MAINTENANCE

9.1 SCHEDULED MAINTENANCE

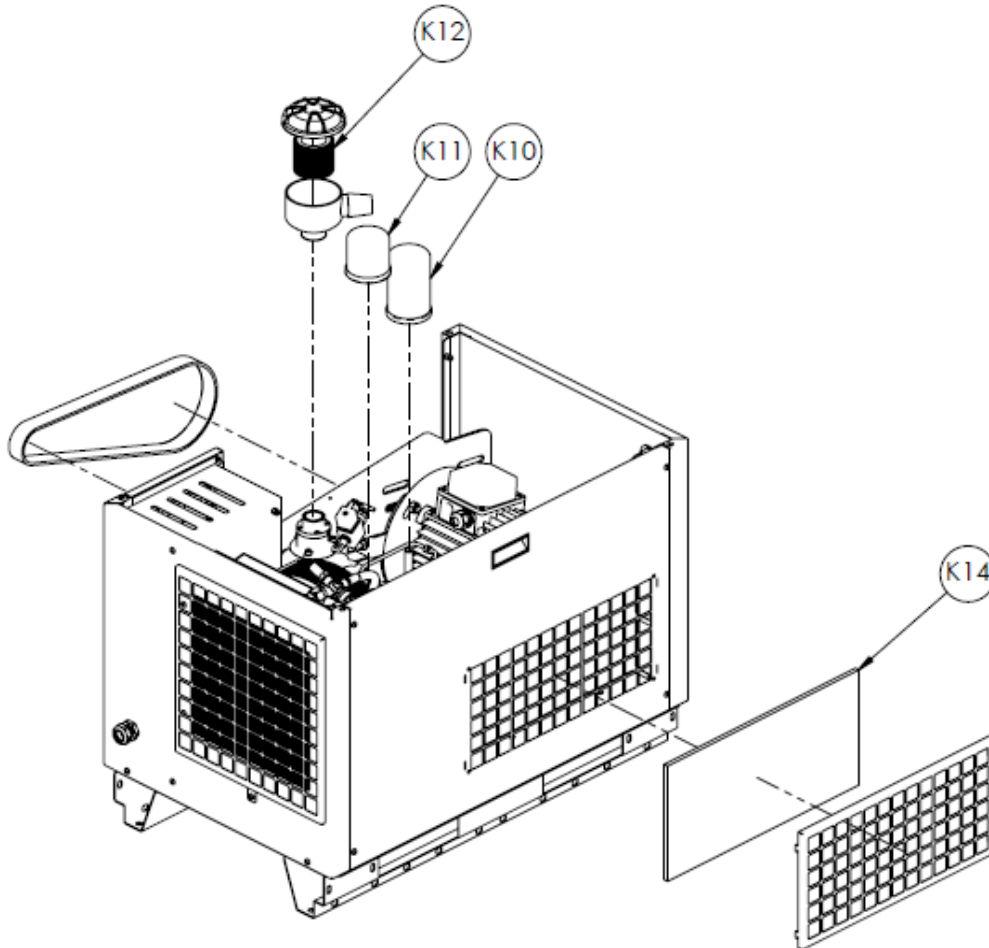

Figure 12



CAUTION!!! USE ONLY ORIGINAL SPARE PARTS!!!



CAUTION!!! HOT PARTS INSIDE!!!

9.1.1 BELT TENSIONING



Make certain that the pulleys installed on the shaft are properly aligned with each other and that the belts are correctly tightened.

For belt drive, we recommend using a “POLY V” belt.

The recommended tension values are given in the table below.



MODEL	TENSION WITH INITIAL NEW BELT [N]	BELT TENSION ALREADY TESTED OR RE-TENSIONING [N]
KV 5,5 8 bar	340	227
KV 5,5 10 bar	340	226
KV 5,5 13 bar	376	251
KV 7,5 8 bar	441	294
KV 7,5 10 bar	440	293
KV 7,5 13 bar	437	292
KV 10 8 bar	544	362
KV 10 10 bar	544	362
KV 10 13 bar	541	84
KV 15 8 bar	810	540
KV 15 10 bar	735	490
KV 15 13 bar	766	511
KV 20 8 bar	927	618
KV 20 10 bar	925	617
KV 20 13 bar	922	615



CAUTION!!!

THE BELT CAN BE TIGHTENED USING AN OPTIKRIK BELT TENSION GAUGE (see chap. 9.1.2)



CAUTION!!!

MAKE CERTAIN THAT THE PULLEYS INSTALLED ON THE SHAFT ARE PROPERLY ALIGNED WITH EACH OTHER AND THAT THE BELTS ARE CORRECTLY TIGHTENED.



CAUTION!!!

EXCESSIVE BELT TENSION DECREASES THE LIFE OF THE SCREW BEARINGS. WHEN THE MACHINE IS RUNNING, THE DRIVE MUST BE PROTECTED TO PREVENT INJURY.

1- Loosen the screws (1) and open the panels (2),(3)

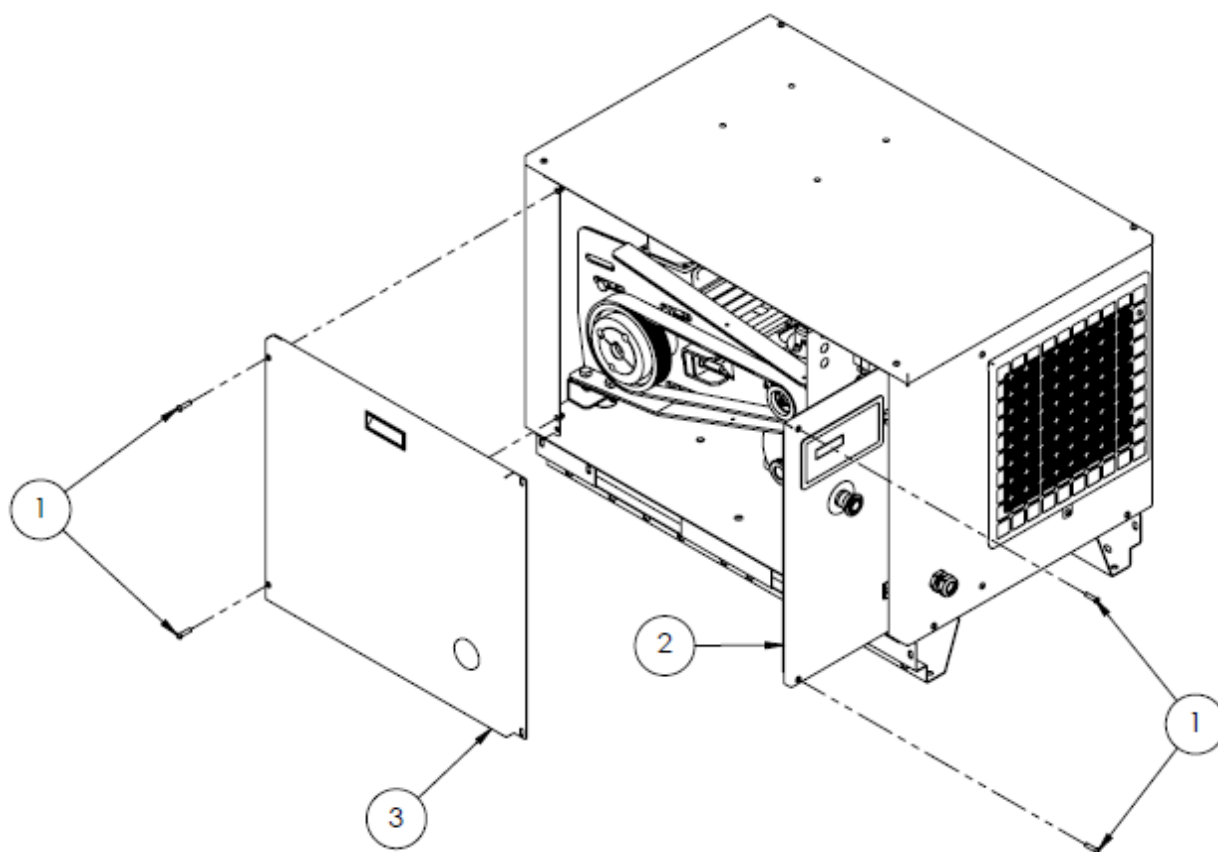

2- Loosen the electric motor fixing screws (7) and (8).

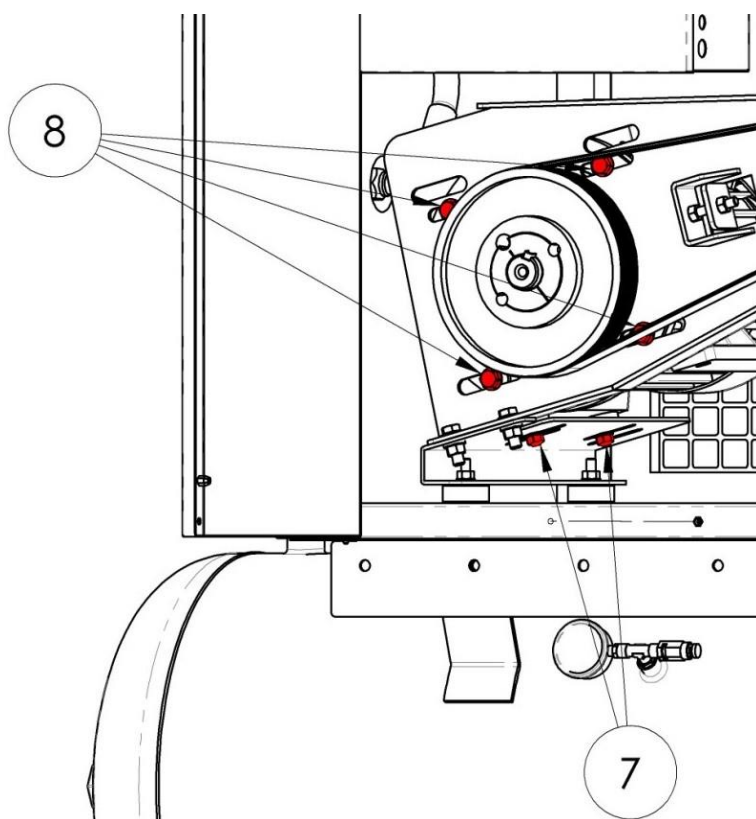

3- To reduce belt tension, loosen nut (10) and tighten nut (9).

To increase belt tension, loosen nut (9) and tighten nut (10) and, once the desired tension has been achieved, close nut (9).

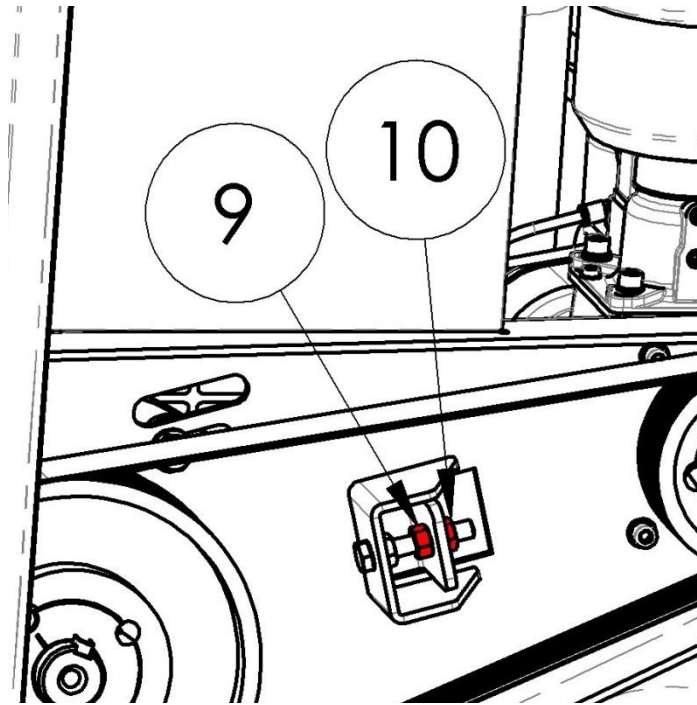

CAUTION!

TO REPLACE THE BELT, LOOSEN NUT (10), MANUALLY GRIP THE SIDES OF THE BELT, RAISE THE MOTOR ALL THE WAY AND LOCK IT IN PLACE WITH THE SCREWS (9).

WITHDRAW THE BELT FROM THE PULLEYS AND REPLACE IT.

THEN, LOOSEN SCREWS (9) AND TIGHTEN THE BELT AS INDICATED AT PAGE 53.

4- Secure the screws (7) to a torque of 85Nm and then tighten screws (6) to a torque of 50Nm.

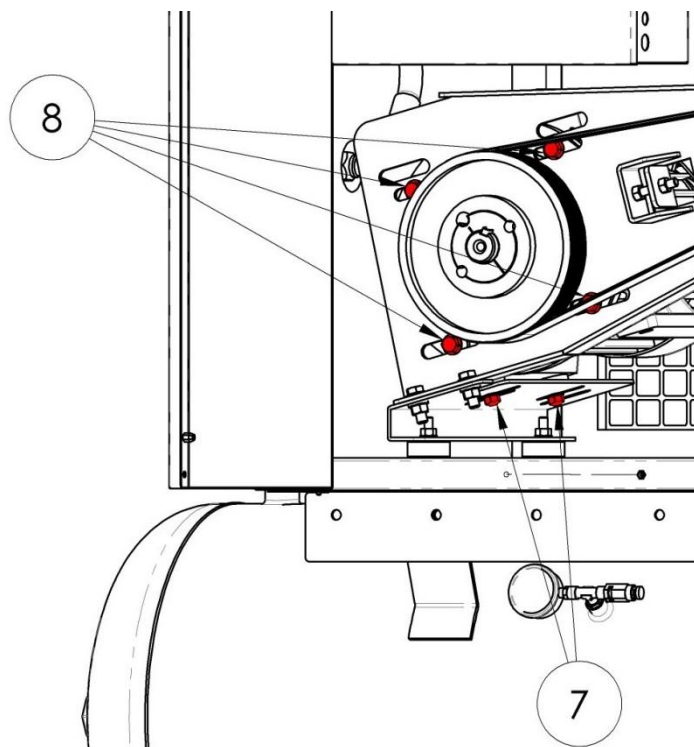

5- Reposition the panels (2)(3) and tighten the screws (1).

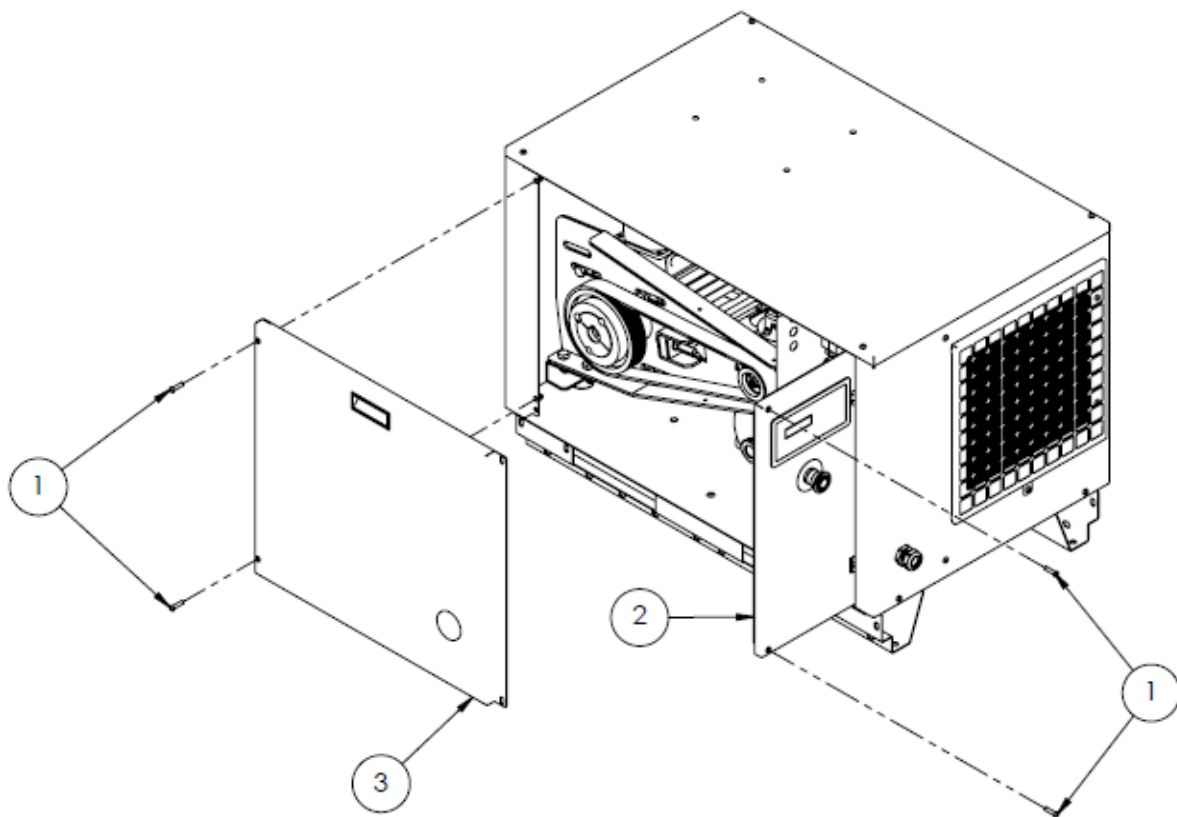

9.1.2 USING AN OPTIKRIK TENSION AUGE

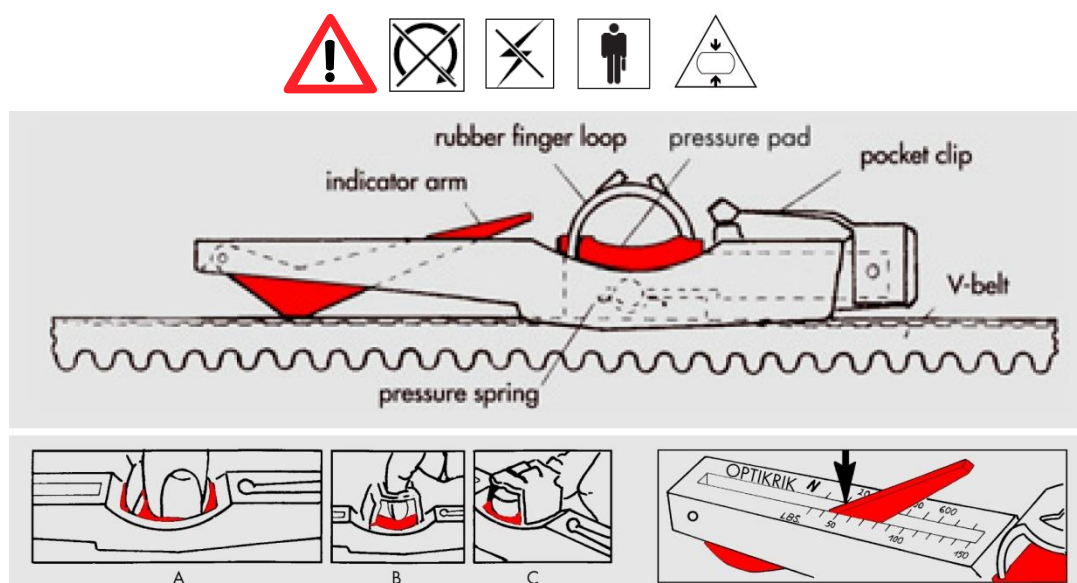

Figure 13

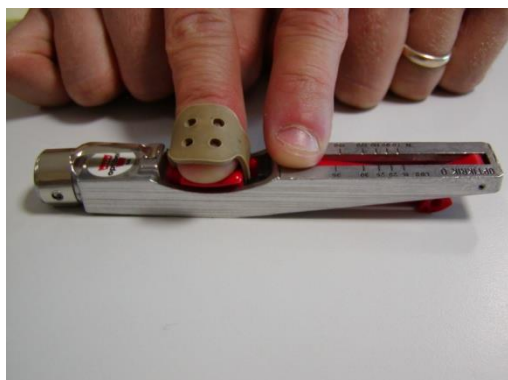

Figure 14



Figure 15

1-Figure 13 (A, B or C) shows the three correct ways to grip the gauge so that the pressure is applied only on the *pressure pad*.

2-Reset the *indicator arm* by lowering it completely as indicated in figure 14.

3-Position the tension gauge on the taut side of the belt, with the part resting of the *indicator arm* set at the mid-point between the pulleys, as indicated in figure 15.

Check gauge alignment ensuring that it is parallel with the belt branch.

4-Press slowly on the *pressure pad*.

When you hear a “click”, immediately stop and remove the tension gauge; this must be done very carefully to prevent compromising the measurement reading taken by the *indicator arm*.

5-Read the tension on the indicator arm as shown in figure 13.

9.1.3 SUCTION PRE-FILTER MAINTENANCE

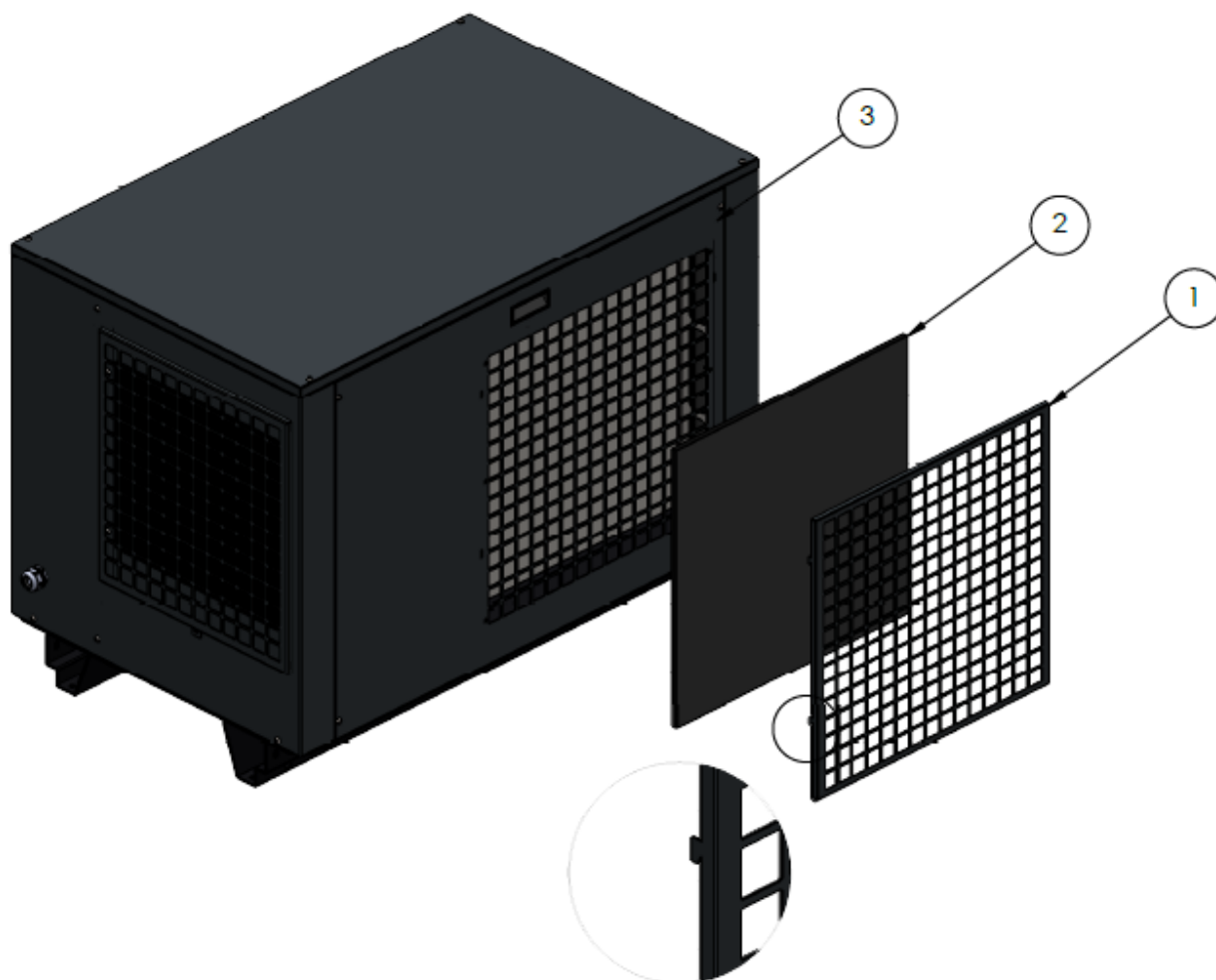

Figure 16

- 1 Raise the protection grid (1) aligning the tabs with the openings on the panel (3).
- 2 Withdraw the protection grid (1) and remove the pre-filter panel (2) so it can be cleaned or replaced.



CLEAN THE PANEL WITH A JET OF AIR OR WASH IT WITH WATER. DO NOT USE SOLVENTS.



THE PRE-FILTER PANEL MUST BE CLEANED OR REPLACED WITH THE MACHINE OFF AND WITH THE UNIT AT ATMOSPHERIC PRESSURE.



OIL LEVEL CHECKS AND TOP UPS MUST BE PERFORMED WITH THE MACHINE OFF AND WITH THE UNIT AT ATMOSPHERIC PRESSURE.



THE OIL REMOVED MUST BE DISCARDED IN COMPLIANCE WITH CURRENT LAW.



IN SEVERE WORKING ENVIRONMENTS (e.g.: PARTICULARLY DUSTY WORK SITES), THE MAINTENANCE INTERVAL MUST BE SHORTER.



**INCORRECT MAINTENANCE OF THE OIL FILTER, AIR FILTER AND OIL SEPARATOR CAN DAMAGE THE UNIT.
LEAVING CARTRIDGES IN OPERATION FOR LONGER THAN THE INDICATED TIME CAN DAMAGE THE COMPRESSOR.**



ALWAYS CAREFULLY COMPLY WITH THE SAFETY WARNINGS REGARDING USE OF THE MACHINE. THIS IS ABSOLUTELY ESSENTIAL.



MAINTENANCE MUST BE CARRIED OUT BY SPECIALISED PERSONNEL. ALWAYS FOLLOW CURRENT ACCIDENT PREVENTION STANDARDS (USE ADEQUATE PROTECTION).

9.1.4 REPLACING THE OIL FILTER



Perform all maintenance as described in this manual or following the indications provided by the retailer or Authorized Service Centre. Open the rear panel and remove the filter cartridge using the special spanner. Then replace the spent cartridge with a new one.

 **Before screwing down the filter cartridge, oil the gasket.
Manually screw down the new cartridge.**



Figure 17

9.1.5 REPLACING THE OIL SEPARATOR FILTER



Replace the oil separator filter after the number of hours indicated in the manual or after checking its differential pressure. To do so, open the rear panel and remove the filter cartridge using the special spanner. Then replace the spent cartridge with a new one.

 **Before screwing down the oil separator cartridge, oil the gasket.
Manually screw down the new cartridge.**



Figure 18

9.1.6 CHANGING THE OIL

Change the oil as indicated in the table point 9.1.8. Extending the number of hours before replacement depends on the type of oil used but in no case can oil be used for more than one year. If the compressor is not used frequently (a couple of hours a day), we recommend changing the oil every 6 months and periodically opening the oil drain cock to check for condensation residues.

 **When the oil drain cock is opened, oil starts flowing out of the screw assembly. Always keep on all necessary equipment to collect the oil.**

Unscrew the oil filling cap on the oil separator tank and open the drain cock.

Once emptied, close the drain cock.

Then top up the oil until the right level is read on the window (see figure 19). Then tighten the oil filling cap once more.

After having replaced the oil and oil filter, run the compressor for about 10 minutes, turn it off and check the oil level. If necessary, top up.

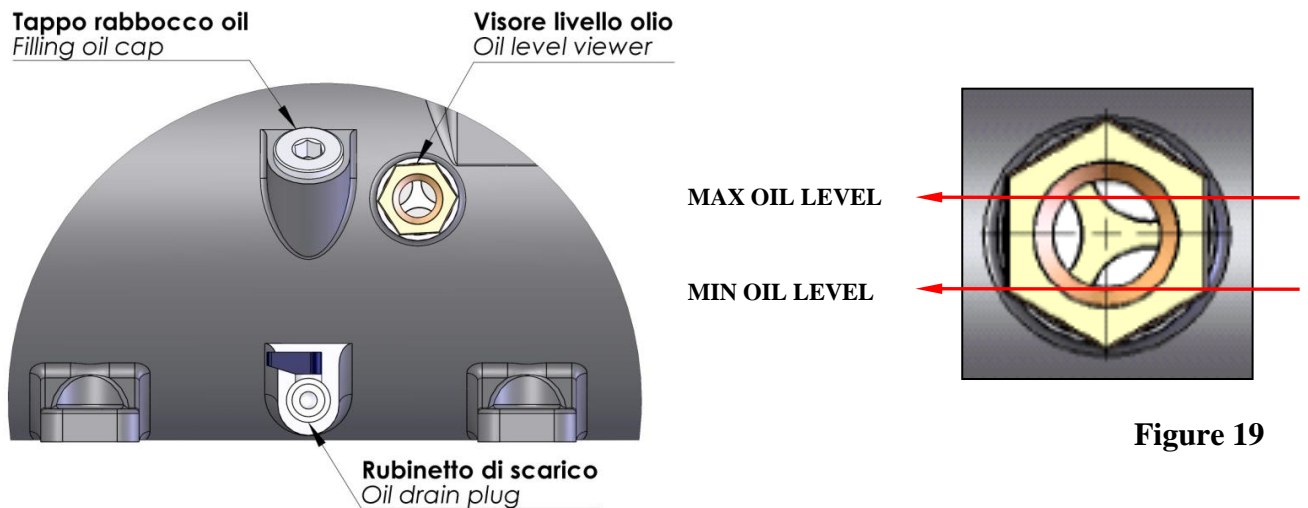



Figure 19

 **Never mix different types of oil. Make certain that the oil circuit is completely empty before performing any maintenance. Always replace the filter at each oil change.**

9.1.7 REPLACING THE AIR FILTER

Replace the cartridge following the indications in the maintenance table; in dusty environments we recommend replacing the filter early, **contact an Authorized Service Centre for information**. To replace the cartridge, unscrew the upper lid. Always clean the container paying particular attention not to let any material fall into the suction valve.



Figure 20

9.1.8 MAINTENANCE SCHEDULE



The table below reports the compressor maintenance schedule.

The hours of operation indicated in the table refer to optimal use of the machine and can thus vary depending on the work site and number of cycles.

The **Manufacturer** recommends keeping a log of the maintenance works performed on the compressor.

MS: Maintenance staff

SP: Service and distribution partners ITALYCO

Component Verification	Maintenance Control Type	HOURS	DESCRIPTION OF OPERATION	Operator control / maintenance
Compressor unit	Visual	Daily	General Inspection unit	MS

Component Verification	Maintenance Control Type	HOURS	DESCRIPTION OF OPERATION	Operator control / maintenance
Oil level	Control	Weekly	level Control	MS
Prefilter air intake	Control		General control and cleaning (if necessary)	
Oil radiators / air	Control		Cleaning (if necessary) of the radiators from various material / powder / oil residues, etc.	

Component Verification	Maintenance Control Type	HOURS	DESCRIPTION OF OPERATION	Operator control / maintenance
Oil filter	Replacement	500	Replacing the oil filter and oil recovery level	SP
Electric / remote control switch panel	Control and tightening		Terminals main electrical panel terminals and contactors star / delta	
Pipes, fittings, components	Control		Visual inspection leaks oil / air	
Belt drive	Control		belt tensioning control and eventual	
Oil cooler	Control		Control of the cooling system efficiency and / temperature	

Component Verification	Maintenance Control Type	HOURS	DESCRIPTION OF OPERATION	Operator control / maintenance
Air filter	Replacement	2000	filter replacement	SP
Oil filter	Replacement		Replacing the oil filter and oil recovery level	
Air separator filter/oil	Replacement		Changing the air / oil separator filter	
Replacing Oil (type Mineral)	Replacement		lubricating oil Substitution	
Main electric motor bearings	Control and greasing		Grease the motor bearings with grease specification	
Belt drive	Control		belt tensioning control and eventual	

Maintenance with mineral oil every 2000 hours

To be repeated at 6000 hours – 10000 hours -14000 -18000 -22000 hours – 26000 hours – 30000 hours – 34000 hours -36000 hours – 38000 hours

Component Verification	Maintenance Control Type	HOURS	DESCRIPTION OF OPERATION	Operator control / maintenance
Air filter	Replacement	4000 or year	filter and pre-filter replacement	SP
Oil filter	Replacement		Replacing the oil filter and oil recovery level	
Air separator filter/oil	Replacement		Changing the air / oil separator filter	
Oil replacement (type Minerale)	Replacement		lubricating oil Substitution	
Oil replacement (type Semi-synthetic /synthetic)	Replacement		lubricating oil Substitution	
Main electric motor bearings	Control and greasing		Grease the motor bearings with grease specification	
Belt drive	Control		belt tensioning control and eventual	
Electric / remote control switch panel	Control and tightening		Terminals main electrical panel terminals and contactors star / delta	

Maintenance with semi-synthetic/synthetic oil every 4000 hours
 To be repeated to 20000 hours -28000 hours -36000 hours

Component Verification	Maintenance Control Type	HOURS	DESCRIPTION OF OPERATION	Operator control / maintenance
Air filter	Replacement	8000	filter and pre-filter replacement	SP
Oil filter	Replacement		Replacing the oil filter and oil recovery level	
Air separator filter/oil	Replacement		Changing the air / oil separator filter	
Oil replacement (type Minerale)	Replacement		lubricating oil Substitution	
Oil replacement (type Semi-synthetic /synthetic)	Replacement		lubricating oil Substitution	
Suction regulator	Revision		Revision vacuum controller with dedicated spare parts kit	
Minimum air pressure regulator	Revision		Revision minimum air pressure controller with dedicated spare parts kit	
Thermostatic oil circuit regulator	Revision		Revision oil thermostatic controller with dedicated spare parts kit	
Main electric motor bearings	Control and greasing		Grease the motor bearings with grease specification	
Electric / remote control switch panel	Control and tightening	Terminals main electrical panel terminals and contactors star / delta		

Component Verification	Maintenance Control Type	HOURS	DESCRIPTION OF OPERATION	Operator control / maintenance
Air filter	Replacement	12000	filter replacement	SP
Oil filter	Replacement		Replacing the oil filter and oil recovery level	
Air separator filter/oil	Replacement		Changing the air / oil separator filter	
Replacing Oil (type Mineral)	Replacement		lubricating oil Substitution	
Replacing Oil (type semi-synthetic/ synthetic)	Replacement		lubricating oil Substitution	
Main electric motor bearings	Control and greasing		Grease the motor bearings with grease specification	
Belt drive	Replacement		Substitution of the belt and its tension	
Electric / remote control switch panel	Control and tightening		Terminals main electrical panel terminals and contactors star / delta	

Component Verification	Maintenance Control Type	HOURS	DESCRIPTION OF OPERATION	Operator control / maintenance
Air filter	Replacement	16000	filter and pre-filter replacement	SP
Oil filter	Replacement		Replacing the oil filter and oil recovery level	
Air separator filter/oil	Replacement		Changing the air / oil separator filter	
Oil replacement (type Mineral)	Replacement		lubricating oil Substitution	
Oil replacement (type synthetic)	Replacement		lubricating oil Substitution	
Suction regulator	Revision		Revision vacuum controller with dedicated spare parts kit	
Minimum air pressure regulator	Revision		Revision minimum air pressure controller with dedicated spare parts kit	
Thermostatic oil circuit regulator	Revision		Revision oil thermostatic controller with dedicated spare parts kit	
Oil Hoses / Air	Replacement		Substitution of the flexible pipes of the oil circuits and air	
Main electric motor bearings	Control and greasing		Grease the motor bearings with grease specification	
Electric / remote control switch panel	Control and tightening	Terminals main electrical panel terminals and contactors star / delta		

Component Verification	Maintenance Control Type	HOURS	DESCRIPTION OF OPERATION	Operator control / maintenance
Air filter	Replacement	24000	filter and pre-filter replacement	SP
Oil filter	Replacement		Replacing the oil filter and oil recovery level	
Air separator filter/oil	Replacement		Changing the air / oil separator filter	
Oil replacement (type Mineral)	Replacement		lubricating oil Substitution	
Oil replacement (type synthetic)	Replacement		lubricating oil Substitution	
Suction regulator	Revision		Revision vacuum controller with dedicated spare parts kit	
Minimum air pressure regulator	Revision		Revision minimum air pressure controller with dedicated spare parts kit	
Thermostatic oil circuit regulator	Revision		Revision oil thermostatic controller with dedicated spare parts kit	
Belt drive	Replacement		Substitution of the belt and its tension	
Main electric motor bearings	Replacement		Replacement of motor bearings (as shown in the table) and greasing with specific fat	
Electric fan bearings	Replacement		Replacing the motor bearings of the fan (as in the table) and greasing with specific fat	
Oil Hoses / Air	Replacement		Substitution of the flexible pipes of the oil circuits and air	
Electric / remote control switch panel	Control and tightening	Terminals main electrical panel terminals and contactors star / delta		

Component Verification	Maintenance Control Type	HOURS	DESCRIPTION OF OPERATION	Operator control/ maintenance
Air filter	Replacement	32000	filter and pre-filter replacement	SP
Oil filter	Replacement		Replacing the oil filter and oil recovery level	
Air separator filter/oil	Replacement		Changing the air / oil separator filter	
Oil replacement (type Mineral)	Replacement		lubricating oil Substitution	
Oil replacement (type synthetic)	Replacement		lubricating oil Substitution	
Suction regulator	Revision		Revision vacuum controller with dedicated spare parts kit	
Minimum air pressure regulator	Revision		Revision minimum air pressure controller with dedicated spare parts kit	
Thermostatic oil circuit regulator	Revision		Revision oil thermostatic controller with dedicated spare parts kit	
Belt drive	Replacement		Substitution of the belt and its tension	
Oil Hoses / Air	Replacement		Substitution of the flexible pipes of the oil circuits and air	
Main electric motor bearings	Control and greasing		Grease the motor bearings with grease specification	
Electric / remote control switch panel	Control and tightening		Terminals main electrical panel terminals and contactors star / delta	

Component Verification	Maintenance Control Type	HOURS	DESCRIPTION OF OPERATION	Operator control / maintenance
Air filter	Replacement	40000	filter and pre-filter replacement	SP
Oil filter	Replacement		Replacing the oil filter and oil recovery level	
Air separator filter/oil	Replacement		Changing the air / oil separator filter	
Oil replacement (type Mineral)	Replacement		lubricating oil Substitution	
Oil replacement (type synthetic)	Replacement		lubricating oil Substitution	
<u>Group-pack smart lives</u>	<u>General review</u>		<u>Full pack-smart lives Revision General</u>	
Seal SCREW motor side	Revision		Replacing oil seal of the main screw shaft with spare parts kit for	
Belt drive	Replacement		Substitution of the belt and its tension	
Main electric motor bearings	Replacement		Replacement of motor bearings (as shown in the table) and greasing with specific fat	
Electric fan bearings	Replacement		Replacing the motor bearings of the fan (as in the table) and greasing with specific fat	
Oil Hoses / Air	Replacement		Substitution of the flexible pipes of the oil circuits and air	
Electric / remote control switch panel	Control and tightening	Terminals main electrical panel terminals and contactors star / delta		

9.2 UNSCHEDULED MAINTENANCE

Unscheduled maintenance must be performed by an Authorized Service Centre.

For any information, please log onto our website www.italyco.net

For any clarifications you may require, contact our **customer services department** or your area **retailer**.



10 TROUBLESHOOTING

Problem	Cause	Resolution
<p>High oil temperature limit trips causing machine to stop.</p>	<p>Low oil level, too high environmental temperature, air/oil cooler clogged, temperature probe failure. Wrong direction of rotation of the fan.</p>	<p>Top up oil level and check that the cooler is clean and the electric fan is functioning properly. Check environmental temperature parameters. Replace temperature probe. Reverse the direction of rotation of the fan.</p>
<p>Motor thermal trip causes machine to stop. Main motor overloaded.</p>	<p>Low line voltage. Phase missing. High pressure of the oil separator.</p>	<p>Check the correct calibration of the thermal protection. Check that the electric power supply is correct. Check that the 3 power phases are at approximately the same value and that the cables are firmly secured to the terminal. Check that the cables are not damaged. Check the main motor ventilation is free of any fouling or foreign objects.</p> <p>If the motor is running in two phases, have it checked by a qualified technician. If necessary, have the motor repaired or replaced.</p> <p>The oil separator differential pressure is above 1.0 bar causing high system absorption. Have the unit checked by qualified personnel. Environmental temperature too high: air the room. To start up the machine again, reset it using the special button on the control panel. Check proper functioning mechanical parts</p>
<p>Fan motor or electric cooling fan thermal trip causing the machine to stop.</p>	<p>The thermal trip for electric fan motor has tripped. High power consumption. High temperature.</p>	<p>Check the correct calibration of the thermal protection. Check that the electric power supply is correct. Check that the 3 power phases are at approximately the same value. Check that the power cords are firmly tightened to the terminal. Check that the power supply cords are not damaged. Check that the cooling fan air intake grid is free of any fouling or foreign objects.</p> <p>If the motor is running in 2 phases, have it checked by a qualified technician. If necessary, have the motor repaired or replaced. Circuit breaker failure, fuse blown, replace the damaged fuse.</p>

Problem	Cause	Resolution
Stopping the machine for operation of the high pressure safety	The pressure exceeds the alarm set point. Transducer does not detect pressure properly. Check if there is a tap "closed" outgoing air of the compressor.	Check the line pressure, release pressure values set it back to work. Check for proper operation of the transducer, if necessary replace it.
Stopping the machine for operation of the low temperature	Oil temperature lower than the value set on the electronic controller. Temperature probe faulty.	In this sequence, if the start button is pressed intermittently, the machine starts in STAR mode and the temperature should return to above the setting. As soon as it does, the machine will automatically start running again. Check the environmental temperature and, if necessary, use a heating resistance on the oil circuit. Contact an authorized Service Centre.
Compressor runs but does not charge.	Suction valve does not open. Auxiliary power disconnected, solenoid valve fuse blown. Breaking transmission elements between the motor and the screw.	Check that the transducer is connected both electrically and pneumatically. Check that the solenoid valve installed on the suction regulator is functioning properly. Check valve or minimum pressure valve failure. Contact an Authorized Service Centre. Check the fuses for the solenoid valve installed on the terminal inside the starter itself. Check and replace the elements of transmission failures.
When starting up the unit for the first time, the machine does not start. Phase anomaly alarm.	The line phases are not correct.	Invert two power supply phases on the main switch. CAUTION!! UNPLUG THE MACHINE.
Oil leaking from air filter.	High oil level, defective suction valve. The compressor during transport has been tilted excessively.	Drain the oil until the correct level is reached. For the valve, contact an Authorized Service Centre.
Opening of the safety valve	Working pressure too high Overpressure in the internal circuit. The oil separator cartridge is clogged.	Restore correct working pressure from rating plate. Replace oil separator filter. Replace any defective safety valve.
Excessive oil consumption.	Oil not suitable for the compressor operation. Air-oil separator cartridge spent or defective. Oil recovery window clogged. Oil level too high.	Replace oil, fill machine with the oil indicated by the manufacturer. Replace oil separator cartridge. Clean or replace oil recovery window. Top up oil until it reaches the level indicated in the manual.

11 COMMERCIAL PARTS, SPARE PARTS AND PERTINENT DOCUMENTATION

For any information, please log onto our website www.italyco.net

For any clarifications you may require, contact our **customer services department** or your area **retailer**.



CAUTION!

- Never touch moving parts while the compressor is running.
- All compressor maintenance operations must be performed with the machine off (at environmental pressure and temperature) and with the unit unplugged.
- Maintenance must be carried out by qualified personnel. Always follow current accident prevention standards (use adequate protection).

The manufacturer reserves the right to make any modifications to the present manual it deems fit and to do so without prior notice.



The manufacturer is relieved of any responsibility for injuries and property damage caused by incorrect use of the compressor assembly, non-compliance or inadequate compliance with the safety criteria indicated herein, modifications (even minor modifications) and by tampering and use of non original spare parts.